



# HISTORIC PRESERVATION COMMISSION REGULAR MEETING

City of Dripping Springs

Council Chambers, 511 Mercer St, Dripping Springs, TX

Thursday, October 01, 2020 at 4:00 PM

---

## VIDEOCONFERENCE MEETING

*This meeting will be held via videoconference and the public is encouraged and welcome to participate. Public comment may be given during the videoconference by joining the meeting using the information below. Public comment for this meeting may also be submitted to the City Secretary at [acunningham@cityofdrippingsprings.com](mailto:acunningham@cityofdrippingsprings.com) no later than 4:00 PM on the day the meeting will be held.*

*The Historic Preservation Commission respectfully requests that all microphones and webcams be disabled unless you are a member of the Commission. City staff, consultants and presenters, please enable your microphone and webcam when presenting to the Commission.*

---

## Agenda

### MEETING SPECIFIC VIDEOCONFERENCE INFORMATION

***Join Zoom Meeting***

<https://us02web.zoom.us/j/89346187246?pwd=WkZrMXJ0dzFHQUIMTWISd0NwcVdBUT09>

***Meeting ID:*** 893 4618 7246

***Passcode:*** 202077

***Dial Toll Free***

877 853 5257 US Toll-free

888 475 4499 US Toll-free

***Find your local number:*** <https://us02web.zoom.us/j/89346187246>

***Join by Skype for Business:*** <https://us02web.zoom.us/skype/89346187246>

### CALL TO ORDER AND ROLL CALL

***Commission Members:***

Bruce Lewis, Chair

Emilie Kopp, Vice Chair

Ashley Bobel

Dean Erickson

Minnie Glosson-Needham

Jean Reimers

Tim Brown

**Staff, Consultants and Appointed/Elected Officials:**

City Administrator Michelle Fischer  
Senior Planner Amanda Padilla  
Planning Assistant Alicia Lundy-Morse  
Mayor Pro Tem Taline Manassian  
Architectural Consultant Keenan Smith

**PRESENTATION OF CITIZENS**

*Each member of the public who desires to address the Historic Preservation Commission regarding any item for an open meeting may do so immediately before or during the Commission's consideration of that item. Citizens wishing to discuss matters not contained within the current agenda may do so, but only during Presentation of Citizens. The Commission may limit the total amount of time the public may speak on a given item. Members of the public requiring the assistance of a translator will be given twice the amount of time as a member of the public who does not require the assistance of a translator to address the Commission. The Commission may not prohibit public criticism of the governmental body, including criticism of any act, omission, policy, procedure, program, or service. This does not apply to public criticism that is otherwise prohibited by law. It is the request of the Commission that members of the public wishing to speak on item(s) on the agenda with a noticed Public Hearing hold their comments until the item(s) are presented for consideration. Speakers are encouraged to sign in. (Section 1. Subchapter A, Chapter 551, Government Code, Section 551.007)*

**MINUTES**

- 1. Discuss and consider approval of the September 3, 2020 Historic Preservation Commission regular meeting minutes.**

**BUSINESS**

- 2. Public hearing and consideration of approval regarding COA2020-0007: Application for Certificate of Appropriateness for exterior restoration of an existing building to be a children's bookstore and building of two one-story buildings (8,000 sqft) to be a Pre-school for a property located at 519 Old Fitzhugh Rd, Dripping Springs, Texas. Applicant: Jon Thompson**

- a) Presentation
- b) Staff Report
- c) Public Hearing
- d) Certificate of Appropriateness

- 3. Public hearing and consideration of approval regarding COA2020-0006: Application for Certificate of Appropriateness for a remodel and construction of addition for property located at 301 U.S. Highway 290 West, Dripping Springs, Texas, and commonly known as Pig Pen BBQ. Applicant: Bill Warren, Pig Pen BBQ**

- a) Presentation
- b) Staff Report
- c) Public Hearing
- d) Certificate of Appropriateness



- 4. Discuss and consider approval of the Historic Preservation Commission 2021 Annual Meeting Calendar.**
- 5. Discuss and consider possible action regarding Historic District Banners.**

## **COMMITTEE REPORTS**

- 6. Parking Lot Improvements Committee**  
*Commissioners Dean Erickson and Tim Brown*
- 7. Landscape Improvements Committee**  
*Commissioners Minnie Glosson-Needham and Jean Reimers*
- 8. Brochure / Printing & Website Committee**  
*Commissioner Emilie Kopp*
- 9. Historic District Signage & Banner Committee**  
*Commissioners Ashley Bobel and Emilie Kopp*

## **EXECUTIVE SESSION**

*The Historic Preservation Commission for the City of Dripping Springs has the right to adjourn into executive session at any time during the course of this meeting to discuss any matter as authorized by Texas Government Code Sections 551.071 (Consultation with Attorney), 551.072 (Deliberations about Real Property), 551.073 Deliberations about Gifts and Donations), 551.074 Personnel Matters), 551.076 (Deliberations about Security Devices), and 551.086 (Economic Development). The Historic Preservation Commission for the City of Dripping Springs may act on any item listed in Executive Session in Open Session or move any item from Executive Session to Open Session for action.*

## **UPCOMING MEETINGS**

### **Historic Preservation Commission Meetings**

November 5, 2020 at 4:00 p.m.

December 3, 2020 at 4:00 p.m.

### **City Council Meetings**

October 13, 2020 at 6:00 p.m.

October 20, 2020 at 6:00 p.m.

## **ADJOURN**

## **TEXAS OPEN MEETINGS ACT PUBLIC NOTIFICATION & POSTING OF MEETING**

*All agenda items listed above are eligible for discussion and action unless otherwise specifically noted. This notice of meeting is posted in accordance with Chapter 551, Government Code, Vernon's Texas Codes. Annotated. In addition, the Commission may consider a vote to excuse the absence of any Commissioner for absence from this meeting.*

*Due to the Texas Governor Order, Hays County Order, City of Dripping Springs Disaster Declaration, and Center for Disease Control guidelines related to COVID-19, a quorum of this body could not be*

*gathered in one place, and this meeting will be conducted through videoconferencing. Texas Government Code Sections 551.045; 551.125; and 551.127.*

*I certify that this notice of meeting was posted at the City of Dripping Springs City Hall and website, [www.cityofdrippingsprings.com](http://www.cityofdrippingsprings.com), on **September 25, 2020 at 1:30 p.m.***

---

*City Secretary*

*This facility is wheelchair accessible. Accessible parking spaces are available. Requests for auxiliary aids and services must be made 48 hours prior to this meeting by calling (512) 858-4725.*



# HISTORIC PRESERVATION COMMISSION REGULAR MEETING

City of Dripping Springs

Council Chambers, 511 Mercer St, Dripping Springs, TX

Thursday, September 03, 2020 at 4:00 PM

## MINUTES

### MEETING SPECIFIC VIDEOCONFERENCE INFORMATION

***Join Zoom Meeting***

<https://us02web.zoom.us/j/89068620182?pwd=cmJlM1NsVkN5Z21YYitFV2Y3UjNlZz09>

***Meeting ID:*** 890 6862 0182

***Passcode:*** 814518

***Dial Toll Free:***

877 853 5257 US Toll-free

888 475 4499 US Toll-free

***Find your local number:*** <https://us02web.zoom.us/j/89068620182>

***Join by Skype for Business:*** <https://us02web.zoom.us/skype/89068620182>

### CALL TO ORDER AND ROLL CALL

***Commission Members present were:***

Bruce Lewis, Chair  
Emilie Kopp, Vice Chair  
Ashley Bobel  
Dean Erickson  
Minnie Glosson-Needham  
Jean Reimers inactive

***Staff, Consultants and Appointed/Elected Officials present were:***

City Administrator Michelle Fischer  
Amanda Padilla, Senior Planner  
Alicia Lundy-Morse, Planning Assistant  
Keenan Smith, Historic Preservation Consultant  
Taline Manassian, Mayor Pro Tem  
Bill Foulds, Mayor  
Lisa Sullivan, Communications Director

With a quorum of the Commission present, Chair Lewis called the meeting to order at 4:04 p.m.

### PRESENTATION OF CITIZENS

*Each member of the public who desires to address the Historic Preservation Commission regarding any item for an open meeting may do so immediately before or during the Commission's consideration of that item. Citizens wishing to discuss matters not contained within the current agenda may do so, but only during Presentation of Citizens. The Commission may limit the total amount of time the public may speak on a given item. Members of the public requiring the assistance of a translator will be given twice the amount of time as a member of the public who does not require the assistance of a translator to address the Commission. The Commission may not prohibit public criticism of the governmental body, including criticism of any act, omission, policy, procedure, program, or service. This does not apply to public criticism that is otherwise prohibited by law. It is the request of the Commission that members of the public wishing to speak on item(s) on the agenda with a noticed Public Hearing hold their comments until the item(s) are presented for consideration. Speakers are encouraged to sign in. (Section 1. Subchapter A, Chapter 551, Government Code, Section 551.007)*

No one spoke at the presentation of citizens

## MINUTES

### 1. **Discuss and consider approval of the August 6, 2020 Historic Preservation Commission regular meeting minutes.**

A motion was made by Commissioner Erickson to approve the August 6, 2020 Historic Preservation regular meeting minutes. Commissioner Glosson-Needham seconded the motion which carried unanimously, 6 to 0.

## BUSINESS

### 2. **Presentation of the Mercer Street History Tour film.**

*Jenny Pack, Executive Director, The Dr. Pound Farmstead*

Jenny Pack presented the film which will air September 19, 2020.

Mayor Foulds and the Commission expressed their praise for the file and requested that it also include the Historic District Brochure.

### 3. **Discuss and consider possible action regarding Committees of the Historic Preservation Commission.**

#### *a) Staff Report*

Michelle Fischer presented the staff report which is on file.

#### *b) Committees*

#### *c) Committee Members*

A motion was made by Commissioner Bobel to remove Commissioner Glosson-Needham from the Parking Lot Improvements Committee and appoint Commissioner Brown to the Parking Lot Improvements Committee. Commissioner Erickson seconded the motion which carried 6 to 0.

## COMMITTEE REPORTS

**5. Parking Lot Improvements Committee**

*Commissioners Dean Erickson and Minnie Glosson-Needham*

No update was given.

**6. Landscape Improvements Committee**

*Commissioners Minnie Glosson-Needham and Jean Reimers*

No update was given.

**7. Brochure / Printing & Website Committee**

*Commissioner Emilie Kopp*

Commissioner Kopp presented the report. The Historic District Brochure is almost complete.

**8. Historic District Signage & Banner Committee**

*Commissioner Ashley Bobel and Emilie Kopp*

Commissioner Bobel presented the report and reviewed the mark ups for the proposed banners, which she will take the feedback to the designers for editing.

**EXECUTIVE SESSION**

*The Historic Preservation Commission for the City of Dripping Springs has the right to adjourn into executive session at any time during the course of this meeting to discuss any matter as authorized by Texas Government Code Sections 551.071 (Consultation with Attorney), 551.072 (Deliberations about Real Property), 551.073 Deliberations about Gifts and Donations), 551.074 Personnel Matters), 551.076 (Deliberations about Security Devices), and 551.086 (Economic Development). The Historic Preservation Commission for the City of Dripping Springs may act on any item listed in Executive Session in Open Session or move any item from Executive Session to Open Session for action.*

The Commission did not meet Executive Session

**UPCOMING MEETINGS****Historic Preservation Commission Meetings**

October 1, 2020 at 4:00 p.m.

November 5, 2020 at 4:00 p.m.

December 3, 2020 at 4:00 p.m.

**City Council Meetings**

September 8, 2020 at 6:00 p.m. (Workshop 6:00 / Regular Meeting 6:30 p.m.)

September 15, 2020 at 6:00 p.m.

**ADJOURN**

A motion was made by Commissioner Bobel to adjourn the. Commissioner Glosson-Needham seconded the motion which carried 6 to 0.

This regular meeting adjourned at 5:10pm.



**HISTORIC PRESERVATION MANUAL  
CERTIFICATE OF APPROPRIATENESS REVIEW**

Date: **September 23, 2020**

Project: **Young Child Academy  
519 Old Fitzhugh Rd, Dripping Springs, TX 78620**

Applicant: **Jon Thompson (512) 568-2184**

Historic District: **Old Fitzhugh Rd Historic District**

Base Zoning: **SF-1 / HO**

Proposed Use: **Mixed Use Rehabilitation- (Zoning Change Required- re: Conditions of Approval #1)**

Submittals:  Current Photograph  Concept Site Plan  Exterior Elevations – Arch'l Elevs  
 Color & Materials Samples - Photomontage

The following review has been conducted for the City of Dripping Springs to determine compliance and consistency with the City of Dripping Springs CODE OF ORDINANCES, Title 2 BUILDING AND DEVELOPMENT REGULATIONS, Chapter 24, BUILDING REGULATIONS, Article 24.07: HISTORIC PRESERVATION, Section 24.07.014: "CRITERIA FOR ISSUANCE OF CERTIFICATE OF APPROPRIATENESS."

**Project Type & Description:**

**"Adaptive Re-use"** of the existing dwelling and shed, which are **Contributing Resources** and **"Medium Preservation Priorities** in the **Old Fitzhugh Rd. Historic District**, as a proposed Children's Bookstore. Also includes **"New Construction"** of two (1) one-story buildings behind the existing structures, with associated parking and site improvements, for a proposed Pre-School use. Existing zoning requires a Zoning Change to permit the proposed uses.

**Review Summary, General Findings: "Approval in Concept With Conditions"**

**General Compliance Determination-**  **Compliant**  Non-Compliant  Incomplete

**City of Dripping Springs**  
P.O. Box 384  
Dripping Springs, Texas 78620  
512-858-4725

**Staff Recommendations: “Approval in Concept with Conditions”**

- 1) **Zoning Change:** shall be processed in conjunction with the City of Dripping Springs Planning Dept and meeting Zoning Ordinance requirements in order to permit the proposed land uses.
- 2) **Necessary Permits:** Any and all required and applicable City of Dripping Springs Permits shall be obtained prior to beginning work (Site Development Permit; Building Permits, at a minimum).
- 3) **Approval in Concept:** Historic Preservation Commission Review & Approval is for Design Concept and COA determination only. City Staff shall review Site Development and Building Permit Submittal Documents for consistency with this COA, prior to issuance of those Permits.
- 4) **Colors - Painted Mural:** Color palette, general design, and artistic themes for proposed hand-painted “Graphical Mural” on the existing historic resource shall be reviewed & approved by Staff prior to Building Permits.
- 5) **Building Materials & Finishes:**
  - a) Painted Masonry (Brick @ Existing chimney) is disallowed by City Historic Preservation Manual Guidelines. Approved material cleaning and restoration techniques & methods shall be used.
  - b) Native Stone Masonry only shall be used (@ Retaining Walls and Veneer). Synthetic Stone products are disallowed. Provide “basis of design” specifications on Permit Drawings.

\* \* \*

**CERTIFICATE OF APPROPRIATENESS:**

**Historic Resource Background / Survey Information:**

**(RFC- Resource Site #14A / 14B; HHM Site No. 50)**

**“#519 Old Fitzhugh Rd. (Bungalow Style Dwelling), ca. 1935, with associated Shed outbuilding: Contributing Resources and a Medium Preservation Priorities.”**

“As it exists today, Old Fitzhugh Road retains buildings and landscape features that reflect the area’s evolution from a nineteenth century agricultural landscape to a circa 1965 residential neighborhood.”

---

**City of Dripping Springs**  
P. O. Box 384  
Dripping Springs, Texas 78620  
512-858-4725



This property retains its architectural integrity and represents a surviving example of a primary dwelling accompanied by the “mostly older domestic and agricultural outbuildings” which characterize the Pre-WWII development of the lower portion of Old Fitzhugh Rd from roughly 1910 - 1935.

“RFC’s medium priority ratings were assigned where alterations and additions have occurred but do not overwhelm the historic-age form and character of the building. For some properties ... medium priority ranking also reflect the presence of historic-age outbuildings and landscape elements that contribute (to) the historic-era setting of the Old Fitzhugh Rd. study area.”

“RFC ... recommends that the City recognize historic-age garages, barns, and other historically intact ancillary structures associated with the recorded primary dwellings as historically contributing features of the Old Fitzhugh Road streetscape.”

**(Source: Roark Foster Consulting- Historic Resources Survey Report & Inventory: 8/5/2014)**

\* \* \*

**Staff Review Summary: #519 OFR – Young Child Academy**

**“Adaptive Re-Use of Existing Dwelling & New Construction Infill Development ”**

The scope of work for this COA consists of two major components reflecting the fundamental programmatic elements of the Young Child Academy operations.

The existing Dwelling and Shed facing Old Fitzhugh Rd. are to be preserved and adaptively re-used as a Children’s Bookstore, with outdoor seating and open-air reading area. The approach to the historic resources respects preservation goals, including cleaning, maintenance, repairs, and selective renovations aimed at maintaining the existing form and character of these two (2) structures. One unusual visual arts concept is a proposed “hand painted mural (artist TBD)” on the façade(s) of the renovated structure. OFR Design and Development Standards do allow a “full range of hues;” w/color palettes to be approved.” In this case, due to the conceptual and creative nature of this feature, further review and secondary approval is recommended as the color palette, general design, and artistic themes of the mural are better defined.

The second development component of the proposed concept entails introduction of two (2) new, one (1)-story buildings behind the existing structures, housing a Pre-School Academy. Preservation of the large number of existing trees has driven a sensitive site planning scheme for these buildings, with its

---

**City of Dripping Springs**  
P.O. Box 384  
Dripping Springs, Texas 78620  
512-858-4725

associated drives, parking (sited to the rear) and other site improvements. The rear of the property slopes gently to a natural watershed drainage. Site engineering will need to incorporate any development-related drainage accommodations and water quality buffer zones. These elements and their layout will be defined, engineered and reviewed by Staff during site development phase. Technical requirements will likely be minimized by the relatively small development footprint and the “low impact” approach. Conceptual Plans show the entire back half of the site left in a relatively undisturbed state, utilized only for Play Areas and Nature Trails for the children.

The proposed design for the infill buildings respects the small-scale character, massing and rooflines of the OFR District, and the architectural approach is consistent with the OFR Design and Development Standards, including Building Footprints, Massing, Articulation, Porches, & Roof requirements. Proposed Materials and Finishes are almost entirely acceptable. One noted exception (detail) is the proposed “Painted Brick” (chimney), which is specifically disallowed by the City’s Historic Preservation Standards. Further materials specification refinements, clarification and approvals are also required for “Native Stone Masonry” (Retaining Walls, Brick Veneer).

At this conceptual phase, Staff generally finds the proposed development and design approach to be appropriate to the scale and character of the Old Fitzhugh Rd. Historic District. The modest development ambition and relatively low impact of the proposed scheme shows both sensitivity and restraint. It respects and preserves the property’s contributing Historic Resources. The careful planning appears to work well with the site’s many existing trees & drainage. The proposed architectural design concepts are appropriate in character. Overall, the proposal is compatible with its surroundings and would fit-in well with the vision and evolution the Old Fitzhugh Road Historic District.

**Staff Findings & Recommendations:**

- 1) **Findings for “Appropriateness.”** Staff finds the approach, design concept & proposal to be consistent with the vision, development guidelines and standards established for the **Old Fitzhugh Rd. Historic District** (see detailed Compliance Review below).
- 2) **Approval in Concept** is recommended. A zoning change is required to permit the proposed uses (Condition of Approval #1). Site Development and Construction Documents shall be reviewed for consistency with this COA prior to issuance of Permits (Conditions of Approval #2, #3).
- 3) **Secondary Review & Approval of Painted Mural** is recommended (Condition of Approval #4).
- 4) **Materials Refinements, Specifications & Approval** is recommended prior to issuance of Permits (Condition of Approval #5).

\* \* \*

---

**City of Dripping Springs**  
P.O. Box 384  
Dripping Springs, Texas 78620  
512-858-4725

### **“Old Fitzhugh Rd. Design and Development Standards”**

**Compliance Review / Statement:** The proposed scope of work as described in the Application and submitted information is found to be appropriate and consistent with applicable design and development standards (Comparative Summary Below), and “Approval with Conditions” is recommended.

**Character/Vision:** Consistent: “Protect Historic Farmstead Scale & Character; Promote Rustic Look/Feel, with Gathering Spaces, etc; New Construction shall be compatible with surroundings.”

**Design Principles:** Consistent: “New Construction shall be compatible with surroundings.”

**Preferred Uses:** Consistent: “Mixed Use Rehab; Residential Rehab or Infill.”

**Site Planning & Building Placement:** Consistent: “Site Buildings within existing trees & landscape features.” Setbacks: Front / Rear > 10’; Sides > 5’ (verify @ Site Development).

**Parking Arrangement:** Consistent: “Onsite Lots @ Rear of Property.”

**Building Footprint / Massing / Scale:** Consistent: Proposed (new) Preschool Buildings. Building #1 = 3,000 GSF < 5,000 max. Building #2 = 5,000 GSF < / = 5,000 max.

**Street Frontage / Articulation:** Consistent: Proposed (new) Preschool Buildings massing meets 45’ max. articulation increment requirements.

**Porches:** Consistent: Proposed (new) Preschool Buildings Canopies & Courtyard Trellises meet Porch requirements.

**Roofs:** Consistent: Proposed (new) Preschool Buildings- 30yr Composition Roofs meet requirements.

**Materials:** Consistent (with exceptions): New materials @ Proposed (new) Preschool Buildings (Sealed Stucco, Shiplap Siding) meet requirements. **Exceptions:** a) Painted Brick Chimney disallowed by guidelines. b) Retaining Walls & Brick Veneer must meet “Native Stone Masonry” requirements. Synthetic Stone products disallowed (Conditions of Approval #5).

**Color Palette:** Consistent (with conditions): Basic proposed color palette meets requirements.

**Conditions:** Hand-painted “Graphical Mural” requires secondary Staff review & approval of Color Palette, General design, and Artistic themes prior to Permits (Conditions of Approval #4).

**Tree Preservation:** Consistent (with conditions): “Trees to be Removed” over 8” dia. shall be replaced per requirements. **Conditions:** Tree Preservation Plan to be reviewed & approved prior to Site Development Permits (Conditions of Approval #2, #3).

**Landscape Features:** N/A- no existing landscape features appear to be affected.

---

**City of Dripping Springs**  
P. O. Box 384  
Dripping Springs, Texas 78620  
512-858-4725

**CRITERIA FOR CERTIFICATE OF APPROPRIATENESS  
(SECTION 24.07.014)**

(a) **STANDARDS & DESIGN GUIDELINES OBSERVED:**  
Project is guided by applicable Historic Preservation Standards and Design Guidelines.

See detailed summary above.  Compliant  Non-Compliant  Not Applicable

(b) **MINIMAL ALTERATION:**  
Reasonable efforts made to adapt property requiring minimal alteration of building, structure, object site & environment.

Compliant  Non-Compliant  Not Applicable

(c) **ORIGINAL QUALITIES PRESERVED:**  
Distinguishing original qualities or characteristics not destroyed. Removal or alteration of historic material or distinguishing architectural features avoided.

Compliant  Non-Compliant  Not Applicable

(d) **PERIOD APPROPRIATENESS:**  
Buildings, structures, objects, sites recognized as products of their own time. Alterations without historic basis or creating an earlier appearance discouraged.

Compliant  Non-Compliant  Not Applicable

(e) **CUMULATIVE & ACQUIRED SIGNIFICANCE:**  
Cumulative changes with acquired and contributing significance are recognized and respected.

Compliant  Non-Compliant  Not Applicable

(f) **DISTINCTIVE STYLISTIC FEATURES & CRAFTSMANSHIP:**  
Distinctive stylistic and characteristic features and examples of skilled craftsmanship are retained where possible.

Compliant  Non-Compliant  Not Applicable

(g) **DETERIORATED ARCHITECTURAL FEATURES:**  
Deteriorated architectural features repaired rather than replaced. Necessary replacements reflect replaced materials. Repair or replacement based on historical evidence not conjecture or material availability.

Compliant  Non-Compliant  Not Applicable

---

**City of Dripping Springs**  
P.O. Box 384  
Dripping Springs, Texas 78620  
512-858-4725

**(h) NON-DAMAGING SURFACE CLEANING METHODS:**  
 Surface Cleaning Methods prescribed are as gentle as possible. No sandblasting or other damaging cleaning methods. (See: “Conditions of Approval #5A”- re: “Painted Brick”)  
 Compliant  Non-Compliant  Not Applicable

**(i) ARCHEOLOGICAL RESOURCES PRESERVED:**  
 Reasonable efforts made to protect and preserve archeological resources affected by, or adjacent to project.  
 Compliant  Non-Compliant  Not Applicable

**(j) CONTEMPORARY DESIGN- CONTEXT SENSITIVE & COMPATIBLE:**  
 Contemporary alterations & additions do not destroy significant historical, architectural, or cultural material and are compatible with the size, scale, color, material and character of the property, neighborhood or environment.  
 Compliant  Non-Compliant  Not Applicable

**(k) RETROVERSION- ESSENTIAL FORM & INTEGRITY UNIMPAIRED:**  
 Future removal of new additions & alterations will leave the essential form & integrity of building, structure, object or site unimpaired.  
 Compliant  Non-Compliant  Not Applicable

**(l) PAINT COLORS- HISTORICAL BASIS:**  
 Paint colors based on duplications or sustained by historical, physical or pictorial evidence, not conjecture. See “Conditions of Approval #4” – Painted Graphical Mural”  
 Compliant  Non-Compliant  Not Applicable

**(m) HISTORIC DISTRICT CONTEXT- OVERALL COMPATIBILITY:**  
 Construction plans are compatible with surrounding buildings and environment vis. height, gross volume and proportion.  
 Compliant  Non-Compliant  Not Applicable

\* \* \*

**APPLICATION FOR CERTIFICATE OF APPROPRIATENESS (SECTION 24.07.015)**

**(g) EXPEDITED PROCESS FOR SMALL PROJECTS: ELIGIBILITY = “Not Eligible”**  
Expedited process for small projects (cumulative costs < \$10,000); must be “No” to all:

- Building Footprint Expansion/Reduction?**       Yes       No
- Façade Alterations facing Public Street or ROW?**       Yes       No
- Color Scheme Modifications?**       Yes       No
- Substantive/Harmful Revisions to Historic District?**       Yes       No

\* \* \*

Please contact (512) 659-5062 if you have any questions regarding this review.



By: **Keenan E. Smith, AIA**  
**Historic Preservation Consultant**

---

**City of Dripping Springs**  
P.O. Box 384  
Dripping Springs, Texas 78620  
512-858-4725



### APPLICATION FOR CERTIFICATE OF APPROPRIATENESS

**Name of Applicant:** Jon Thompson, J Thompson Professional Consulting, LLC

**Mailing Address:** PO Box 172, Dripping Springs, Texas 78620

**Phone Number:** (512) 568-2184      **Email Address:** jthompsonconsultingds@gmail.com

**Name of Owner (if different than Applicant):** Estates of Charlie N. Haydon

**Mailing Address:** \_\_\_\_\_

**Phone Number:** \_\_\_\_\_

**Address of Property Where Structure/Site Located:** \_\_\_\_\_

519 Old Fitzhugh Rd. Dripping Springs, TX 78620

**District Located or Landmark:**  Mercer Street     Old Fitzhugh Road     Hays Street

Individual Landmark (Not in an Historic District)

**Zoning Classification of Property:** SF-1

**Proposed Use of Property (reference Land Use Chart in Zoning Ordinance):**

Mix Used Rehab - OFR

**Description of Proposed Work:** A proposed Adaptive Re-Use project consisting of a Bookstore with outdoor seating and open air reading area and a new Pre-School approximately 8,000 SF. The Bookstore component will adapt a historically designated structure/house along with a contributing wood shed. The Pre-School will be new construction of two one-story buildings, located behind the existing historic structure. The new design will comply with the requirements of the Historic Preservation Commission and be as sensitive as possible to preserve the existing trees on site.



**Description of How Proposed Work will be in Character with Architectural and/or Historical Aspect of Structure/Site and the Applicable Zoning Requirements:**

The work proposed on the historic house and wood shed will be mainly cosmetic. The exterior of the house will be restored by repairing damaged trim and siding while maintaining the original detailing. The existing windows will be restored to the extent possible. The wood shed will be restored in similar fashion and converted to an outdoor reading area. The proposed new pre-school structures will remain one-story and as far back on the site as appropriate so as to not compete with existing historic house. The exterior of the buildings will be siding and masonry elements that are in compliance with zoning requirements. Minimal trees will be removed.

**Estimated Cost of Proposed Work:** \$1,750,750.00

**Intended Starting Date of Proposed Work:** Winter 2020

**Intended Completion Date of Proposed Work:** Summer 2021

**ATTACH THE FOLLOWING DOCUMENTS (in a form acceptable to the City):**

- Current photograph of the property and adjacent properties (view from street/right-of-way)
- Concept Site Plan: A drawing of the overall conceptual layout of a proposed development, superimposed upon a topographic map or aerial photo which generally shows the anticipated plan of development
- Elevation drawings/sketches of the proposed changes to the structure/site
- Samples of materials to be used
- Color chips of the colors which will be used on the structure (if applicable)
- Sign Permit Application (if applicable)
- Building Permit Application (if applicable)
- Application for alternative exterior design standards and approach (if applicable)
- Supplemental Design Information (as applicable)

*Jon Thompson*

Signature of Applicant

September 14, 2020

Date

DocuSigned by:

*Winnie R*

B16D7D6FF28C45C...

Signature of Property Owner Authorizing the Proposed Work

Date

\*\*\*\*\**TO BE FILLED OUT BY CITY STAFF*\*\*\*\*\*

Date Received: \_\_\_\_\_ Received By: \_\_\_\_\_

Project Eligible for Expedited Process:  Yes  No

Action Taken by Historic Preservation Officer:  Approved  Denied

Approved with the following Modifications: \_\_\_\_\_

\_\_\_\_\_  
\_\_\_\_\_  
\_\_\_\_\_

Signature of Historic Preservation Officer

Date

Date Considered by Historic Preservation Commission (if required): \_\_\_\_\_

Approved  Denied

Approved with the following Modifications: \_\_\_\_\_

\_\_\_\_\_  
\_\_\_\_\_  
\_\_\_\_\_

Historic Preservation Commission Decision Appealed by Applicant:  Yes  No

Date Appeal Considered by Planning & Zoning Commission (if required): \_\_\_\_\_

Approved  Denied

Approved with the following Modifications: \_\_\_\_\_

\_\_\_\_\_  
\_\_\_\_\_  
\_\_\_\_\_

Planning & Zoning Commission Decision Appealed by Applicant:  Yes  No

Date Appeal Considered by City Council (if required): \_\_\_\_\_

Approved  Denied

Approved with the following Modifications: \_\_\_\_\_

\_\_\_\_\_  
\_\_\_\_\_  
\_\_\_\_\_

*Submit this application to City Hall at 511 Mercer St./P.O. Box 384, Dripping Springs, TX 78620. Call City Hall at (512)858-4725 if you have questions regarding this application.*

SCOPE OF WORK:

1. Restore the exterior of the original house by repairing the existing trim and siding while maintaining the original detailing.
2. Restore the windows where ever possible and replace when adding new to match the original as closely as possible.
3. The front and side yards will be converted to outdoor lounge and reading areas.
4. The original wod shed, a countributing structure, will be restored and converted into an outdoor reading room/ accoustic music venue - by opening up the side facing the original house.
5. A graphical facelift to the bungalow with a hand-painted mural (artist tbd).



BOOKSTORE RENOVATION  
STREET VIEW ELEVATION

Young Child Academy  
519 Old Fitzhugh Road  
Dripping Springs, TX

# Materials and Finishes

## Retaining Walls:

Weston Stone

3 PIECE

4 x 8 x 8

4 x 12 x 8

4 x 16 x 8

Weston Universal

4 x 12 x 8

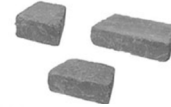

## Brick Veneer:

Silvermine Stone

6 in x 24 in. PIECE

Stone Veneer



## Sealed Tinted Stucco:

SW 0052 Pearl Grey by Sherwin Williams



## 8" Shiplap Rain Screen:

Shiplap Pattern

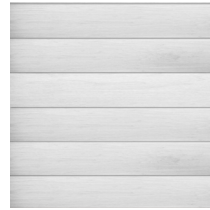

SW 0052 Pearl Grey by Sherwin Williams



SW 6701 Moonraker by Sherwin Williams



## 30 Yr Composition Roof:

Color/Finish: Estate Gray:

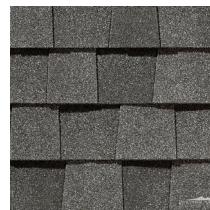

## Materials and Finishes

**STEEL FRAME WITH  
RETRACTABLE FABRIC  
AWNING:**





DRIPPING SPRINGS OUTFITTERS, LLC.  
4.39 ACRES  
(DOC. NO. 17032696)

DEBORAH CARTER  
0.504 ACRES  
(DOC. NO. 11020892)

BARBARA JANNARD  
0.518 ACRES  
(DOC. NO. 18037856)



CONSULTANTS

KEY PLAN

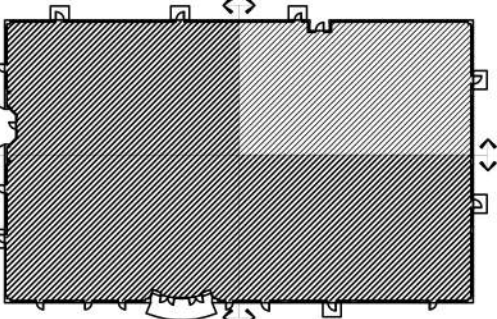

PROJECT NAME

Young Child Academy  
519 Old Fitzhugh Road  
Dripping Springs, TX

Adaptive Reuse

IF THIS DOCUMENT IS NOT SIGNED,  
SEALED, AND DATED, IT MAY NOT BE  
USED FOR REGULATORY APPROVAL,  
PERMIT, OR CONSTRUCTION.  
© Daniel Scott Turner, 2019

REVISION # DATE

01 ARCHITECTURAL SITE PLAN  
1/16" = 1'-0"

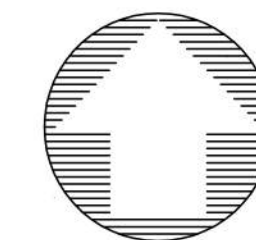

PLAN NORTH

SHEET TITLE(S)

ARCHITECTURAL  
SITE PLAN

REVISION DATE:

ISSUE DATE: 2020-09-15

PROJECT NUMBER: 20105

A0.1.1





CONSULTANTS	

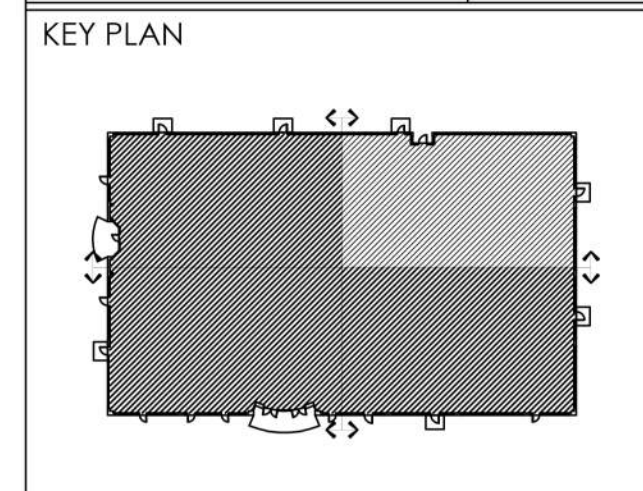

PROJECT NAME  
Young Child Academy  
519 Old Fitzhugh Road  
Dripping Springs, TX

Adaptive Reuse

IF THIS DOCUMENT IS NOT SIGNED,  
SEALED, AND DATED, IT MAY NOT BE  
USED FOR REGULATORY APPROVAL,  
PERMIT, OR CONSTRUCTION.  
© Daniel Scott Turner, 2019

REVISION # \_\_\_\_\_ DATE \_\_\_\_\_

01 ARCHITECTURAL SITE PLAN  
1" = 30'-0"

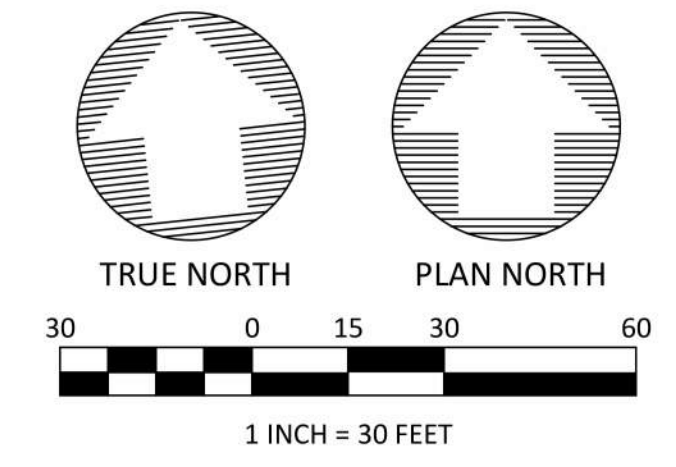

SHEET TITLE(S)  
SITE PARKING  
PLAN

REVISION DATE: \_\_\_\_\_  
ISSUE DATE: 2020-09-15  
PROJECT NUMBER: 19110

A0.1.2



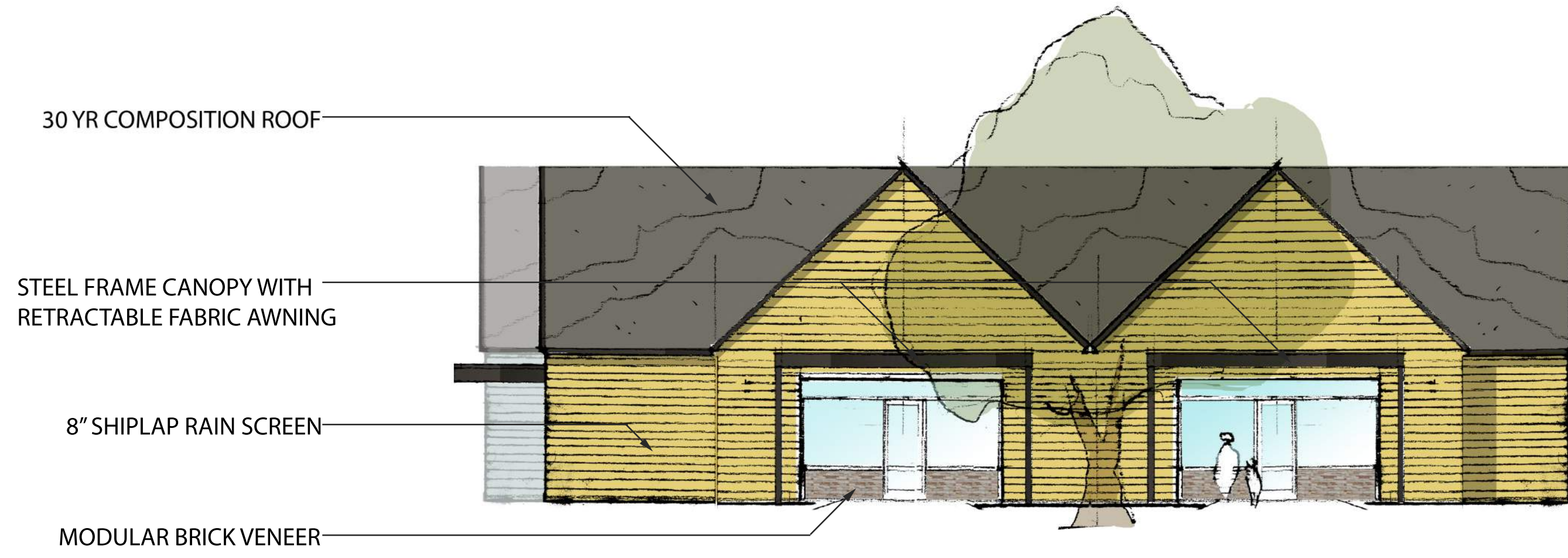

YOUNG CHILD ACADEMY - DRIPPING SPRINGS  
1/8" = 1'-0" STREET ELEVATION

CONSULTANTS	

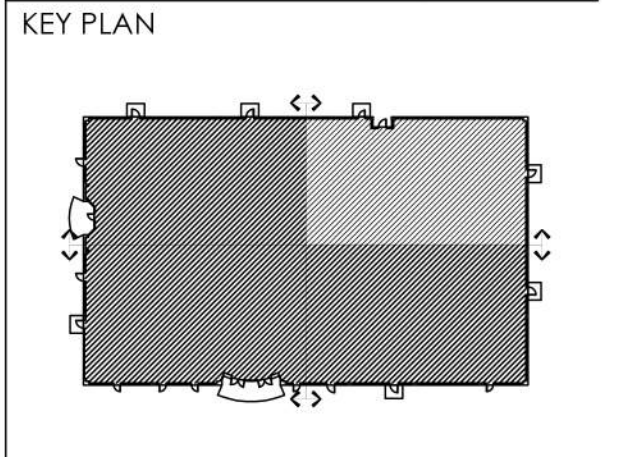

PROJECT NAME  
Young Child Academy  
519 Old Fitzhugh Road  
Dripping Springs, TX

Adaptive Reuse

IF THIS DOCUMENT IS NOT SIGNED,  
SEALED, AND DATED, IT MAY NOT BE  
USED FOR REGULATORY APPROVAL,  
PERMIT, OR CONSTRUCTION.  
© Daniel Scott Turner, 2019

REVISION # \_\_\_\_\_ DATE \_\_\_\_\_

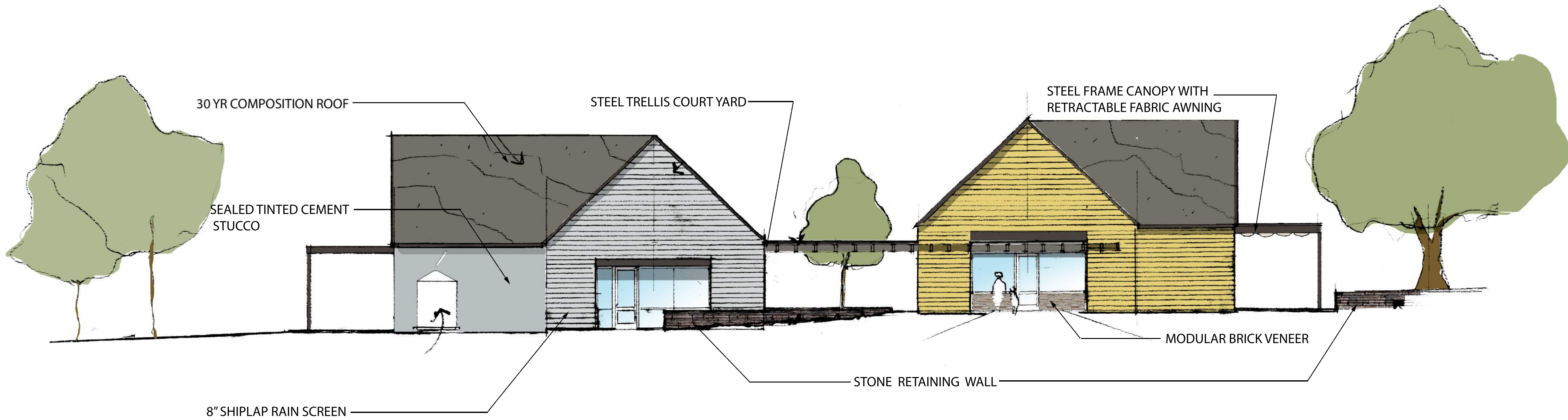

YOUNG CHILD ACADEMY - DRIPPING SPRINGS  
1/8" = 1'-0" SOUTH ELEVATION

SHEET TITLE(S)  
ARCHITECTURAL  
ELEVATIONS

REVISION DATE: \_\_\_\_\_  
ISSUE DATE: 2020-09-15  
PROJECT NUMBER: 20105











































































**HISTORIC PRESERVATION MANUAL  
CERTIFICATE OF APPROPRIATENESS REVIEW**

Date: **September 22, 2020**

Project: **Pig Pen BBQ / CP 290 LLC  
301 US 290W, Dripping Springs, TX 78620**

Applicant: **Bill Warren (512) 560-7528 / Dusty Dennis- Owners (210) 621-3288**

Historic District: **Hays Street Historic District**

Base Zoning: **CS-HO**

Proposed Use: **BBQ Restaurant- (existing use unchanged)**

Submittals:  Current Photograph  Concept Site Plan  Exterior Elevations – Arch’l Elevs  
 Color & Materials Samples - Photomontage

The following review has been conducted for the City of Dripping Springs to determine compliance and consistency with the City of Dripping Springs CODE OF ORDINANCES, Title 2 BUILDING AND DEVELOPMENT REGULATIONS, Chapter 24, BUILDING REGULATIONS, Article 24.07: HISTORIC PRESERVATION, Section 24.07.014: “CRITERIA FOR ISSUANCE OF CERTIFICATE OF APPROPRIATENESS.”

**Project Type & Description:**

**“Screened Cooking Porch Addition & Misc. Minor Alterations”** to the main existing restaurant structure, a **Non-Contributing Resource** in the **Hays St. Historic District**.

**Review Summary, General Findings: “Approval in Concept With Conditions”**

**General Compliance Determination-**  **Compliant**  Non-Compliant  Incomplete

**City of Dripping Springs**  
P.O. Box 384  
Dripping Springs, Texas 78620  
512-858-4725

**Staff Recommendations: “Approval in Concept with Conditions”**

- 1) **Necessary Permits:** Any and all required and applicable City of Dripping Springs Permits shall be obtained prior to beginning work (Building Permit plus Site Development Permit, if needed).
- 2) **Approval in Concept:** Historic Preservation Commission Review & Approval is for Design Concept and COA determination only. City Staff shall review Permit Submittal Construction Documents for consistency with this COA, prior to issuance of Building Permits.

**CERTIFICATE OF APPROPRIATENESS:**

**Historic Resource Background / Survey Information:**

**#301 US 290W (FKA Creek Road Cafe):**

**Construction dating from 1980’s, with numerous addition and outbuildings. “Non-Contributing.”**

**(Not referenced in any applicable Historic Resource Survey on file).**

**“W. T. Chapman, Original Plat, Block Nine, Lots 6, 7”**

Carl Waits’ book, in the chapter “History of Land Ownership,” chronicles the land ownership sequence. In his conclusion, there is a brief mention of this property’s beginnings as a restaurant use: “These two lots were sold to Jesse “Mike” Poston in the early 80’s. He built a restaurant on Lot 6.” (p. 203)

**Waits, Carl- “A Complete History of Dripping Springs and the P. A. Smith Survey” Austin, TX Nortex Press, - (2003).**

\* \* \*

**Staff Review Summary:**

**“Screened Cooking Porch Addition & Misc. Minor Alterations”**

The scope of work for this COA proposes the addition of a 957 SF covered, steel-framed, Screened Cooking Porch at the rear of the existing structure, to house the outdoor cooking pits for the proposed BBQ restaurant use. Metal Screening Panels and Cedar Plank Screen Boards complete the enclosure.

Proposed repairs to the main structure include removal and replacement of the existing metal roofing with “weathered galvalume corrugated metal roofing panels to match new roofing panels installed over screened cooking porch” (see proposed Exterior Color & Materials photomontage).

---

**City of Dripping Springs**  
 P. O. Box 384  
 Dripping Springs, Texas 78620  
 512-858-4725

The rest of the proposed exterior alterations to the existing structure are minor. A small existing Water Heater & Enclosure (bump-out) protruding from the Right (West) Elevation is to be removed, with siding replaced & painted to match, and a new wall-mounted Tankless Water Heater mounted in it's place. Aside from necessary maintenance and repairs (with any materials replaced "in kind") there are no other exterior alterations proposed. The existing conditions and appearance of the Front (US 290 / Entry), Left (College St.) Elevations, as well as the four (4) separate, freestanding, existing Outbuildings on the property, are to remain essentially unaltered (see "Existing & Remodel" Elevations).

Staff finds the proposed design approach to be appropriate to the scale and character of the Hays St. Historic District. It represents a "light touch" remodel, promoting the preservation and adaptive re-use of the existing restaurant structure, and resulting in renewal and revitalization of a shuttered building. The new "Screened Cooking Porch Addition" at the rear is appropriately scaled, compatible with the building, integrates well with the existing rooflines, and harmonizes with the new corrugated metal roofs. The minor Water Heater Enclosure alterations described above "cleanup" and redresses the cluttered Right (West) Elevation.

The existing building footprints remain relatively unchanged, aside from the addition of the New Screened Cooking Porch (an approx. 24% increase in GSF). This proposal preserves the main structure's essential forms, massing, and primary building materials, while maintaining the rambling and informal look, feel & architectural character.

**Staff Findings & Recommendations:**

- 1) **Findings for "Appropriateness."** Staff finds the approach, design concept & proposal to be consistent with the vision, development guidelines and standards established for the **Hays St. Historic District** (see detailed Compliance Review below).
- 2) **Approval in Concept** is recommended. Construction Documents shall be reviewed for consistency with this COA prior to issuance of Building Permits (Condition of Approval #2).

\* \* \*

**"Mercer Street Design and Development Standards"**

**Compliance Review / Statement:** The proposed scope of work as described in the Application and submitted information is found to be appropriate and consistent with applicable design and development standards (Comparative Summary Below), and "Approval with Conditions" is therefore recommended.

**Character/Vision:** Consistent: "Preserve Historic Resources- Rehab & Adaptive Re-Use; Promote Revitalization."

---

**City of Dripping Springs**  
 P. O. Box 384  
 Dripping Springs, Texas 78620  
 512-858-4725



**Design Principles:** Consistent: “New Construction shall be compatible with surroundings.”

**Preferred Uses:** Consistent: “Full Mix of Uses Allowed.”

**Site Planning & Building Placement:** N/A- (Existing) Building Placement not affected.

**Parking Arrangement:** N/A- (Existing) Parking Arrangement not affected.

**Building Footprint / Massing / Scale:** Consistent: The proposed 957 SF addition does not significantly affect the Building Footprint, Massing & Scale. (957 SF New / 3922SF Existing = 24.4% Addition).

**Street Frontage / Articulation:** N/A- (Existing) Building Frontage Configuration not affected.

**Porches:** N/A- (Existing) Building Configuration not affected.

**Roofs:** N/A- (Existing) Building Roof not affected.

**Materials:** Consistent: New materials (metal roofing panels & screening, cedar planking) consistent with Existing Building & context.

**Color Palette:** Consistent: Maintain / repaint existing building. “Cedar Plank Screen Boards” ... consistent with Existing Building & context. OK.

**Tree Preservation:** N/A- No proposed impact to any existing trees.

**Landscape Features:** N/A- no existing landscape features affected.

\* \* \*

**CRITERIA FOR CERTIFICATE OF APPROPRIATENESS**  
**(SECTION 24.07.014)**

**(a) STANDARDS & DESIGN GUIDELINES OBSERVED:**  
Project is guided by applicable Historic Preservation Standards and Design Guidelines.

See detailed summary above.  Compliant  Non-Compliant  Not Applicable

**(b) MINIMAL ALTERATION:**  
Reasonable efforts made to adapt property requiring minimal alteration of building, structure, object site & environment.

Compliant  Non-Compliant  Not Applicable

---

**City of Dripping Springs**  
P.O. Box 384  
Dripping Springs, Texas 78620  
512-858-4725



- (c) **ORIGINAL QUALITIES PRESERVED:**  
Distinguishing original qualities or characteristics not destroyed. Removal or alteration of historic material or distinguishing architectural features avoided.
- Compliant  Non-Compliant  Not Applicable
- (d) **PERIOD APPROPRIATENESS:**  
Buildings, structures, objects, sites recognized as products of their own time. Alterations without historic basis or creating an earlier appearance discouraged.
- Compliant  Non-Compliant  Not Applicable
- (e) **CUMULATIVE & ACQUIRED SIGNIFICANCE:**  
Cumulative changes with acquired and contributing significance are recognized and respected.
- Compliant  Non-Compliant  Not Applicable
- (f) **DISTINCTIVE STYLISTIC FEATURES & CRAFTSMANSHIP:**  
Distinctive stylistic and characteristic features and examples of skilled craftsmanship are retained where possible.
- Compliant  Non-Compliant  Not Applicable
- (g) **DETERIORATED ARCHITECTURAL FEATURES:**  
Deteriorated architectural features repaired rather than replaced. Necessary replacements reflect replaced materials. Repair or replacement based on historical evidence not conjecture or material availability.
- Compliant  Non-Compliant  Not Applicable
- (h) **NON-DAMAGING SURFACE CLEANING METHODS:**  
Surface Cleaning Methods prescribed are as gentle as possible. No sandblasting or other damaging cleaning methods.
- Compliant  Non-Compliant  Not Applicable
- (i) **ARCHEOLOGICAL RESOURCES PRESERVED:**  
Reasonable efforts made to protect and preserve archeological resources affected by, or adjacent to project.
- Compliant  Non-Compliant  Not Applicable

(j) **CONTEMPORARY DESIGN- CONTEXT SENSITIVE & COMPATIBLE:**  
Contemporary alterations & additions do not destroy significant historical, architectural, or cultural material and are compatible with the size, scale, color, material and character of the property, neighborhood or environment.  
 Compliant  Non-Compliant  Not Applicable

(k) **RETROVERSION- ESSENTIAL FORM & INTEGRITY UNIMPAIRED:**  
Future removal of new additions & alterations will leave the essential form & integrity of building, structure, object or site unimpaired.  
 Compliant  Non-Compliant  Not Applicable

(l) **PAINT COLORS- HISTORICAL BASIS:**  
Paint colors based on duplications or sustained by historical, physical or pictorial evidence, not conjecture.  
 Compliant  Non-Compliant  Not Applicable

(m) **HISTORIC DISTRICT CONTEXT- OVERALL COMPATIBILITY:**  
Construction plans are compatible with surrounding buildings and environment vis. height, gross volume and proportion.  
 Compliant  Non-Compliant  Not Applicable

**APPLICATION FOR CERTIFICATE OF APPROPRIATENESS (SECTION 24.07.015)**

(g) **EXPEDITED PROCESS FOR SMALL PROJECTS: ELIGIBILITY = “Not Eligible”**  
Expedited process for small projects (cumulative costs < \$10,000); must be “No” to all:

**Building Footprint Expansion/Reduction?**  Yes  No  
**Facade Alterations facing Public Street or ROW?**  Yes  No  
**Color Scheme Modifications?**  Yes  No  
**Substantive/Harmful Revisions to Historic District?**  Yes  No

\* \* \*

Please contact (512) 659-5062 if you have any questions regarding this review.



By: **Keenan E. Smith, AIA**  
**Historic Preservation Consultant**

---

**City of Dripping Springs**  
P.O. Box 384  
Dripping Springs, Texas 78620  
512-858-4725



# CITY OF DRIPPING SPRINGS

PHYSICAL: 511 Mercer Street • MAILING: PO Box 384

Dripping Springs, TX 78620

• 512.858.4725 • www.cityofdrippingsprings.com

## CERTIFICATE OF APPROPRIATENESS APPLICATION

District Located or Landmark:  Mercer Street  Old Fitzhugh Road  Hays Street

Individual Landmark (Not in an Historic District)

### CONTACT INFORMATION

APPLICANT NAME: Pig Pen BBQ (Bill Warren)

STREET ADDRESS: 1005 W. Hwy. 290, Dripping Springs, TX 78620

PHONE: 512.560.7528 EMAIL: ranchero302@hotmail.com

PROPERTY OWNER NAME (if different than Applicant): CP 290 LLC (Dusty Dennis)

STREET ADDRESS: 607 Loving Ct., Southlake, TX 76092

PHONE: 210.621.3288 EMAIL: ddennis@creedpartners.com

### PROJECT INFORMATION

Address of Property (Structure/Site Location): 301 U.S. Highway 290 West

Zoning Classification of Property: CS

Description of Proposed Use of Property/ Proposed Work: BBQ restaurant adding a metal framed, open air, screened cooking porch for BBQ pits at rear of building and demo of water heater exterior closet to be replaced with tankless water heater unit installed on wall vacated by closet structure.

Description of How Proposed Work will be in Character with Architectural and/or Historical Aspect of Structure/Site and the Applicable Zoning Requirements: Phase 1 remodel/addition will have the appearance of a large screened porch and the corrugated roofing to be installed on the main building and new porch will match the character of many of the historic structures on Mercer Street and be more appropriate than the more commercial metal panel profile now on the building.

Estimated Cost of Proposed Work: \$ 8500.00

Intended Start Date of Work: ASAP Intended Completion Date of Work: 3 months from start date

**CERTIFICATE OF APPROPRIATENESS SUBMITTAL CHECKLIST**

CHECKLIST		
Staff	Applicant	
<input type="checkbox"/>	<input checked="" type="checkbox"/>	Current photograph of the property and adjacent properties (view from street/right-of-way)
<input checked="" type="checkbox"/>	<input checked="" type="checkbox"/>	Concept Site Plan: A drawing of the overall conceptual layout of a proposed development, superimposed upon a topographic map or aerial photo which generally shows the anticipated plan of development
<input type="checkbox"/>	<input checked="" type="checkbox"/>	Elevation drawings/sketches of the proposed changes to the structure/site
<input type="checkbox"/>	<input checked="" type="checkbox"/>	Samples of materials to be used
<input type="checkbox"/>	<input checked="" type="checkbox"/>	Color chips of the colors which will be used on the structure <i>(if applicable)</i>
<input type="checkbox"/>	<input type="checkbox"/>	Sign Permit Application <i>(if applicable)</i>
<input type="checkbox"/>	<input type="checkbox"/>	Building Permit Application <i>(if applicable)</i>
<input type="checkbox"/>	<input type="checkbox"/>	Application for alternative exterior design standards and approach <i>(if applicable)</i>
<input type="checkbox"/>	<input checked="" type="checkbox"/>	Supplemental Design Information <i>(as applicable)</i>
<input type="checkbox"/>	<input checked="" type="checkbox"/>	Billing Contact Form
<input type="checkbox"/>	<input type="checkbox"/>	Proof of Ownership-Tax Certificate or Deed

  
 \_\_\_\_\_  
 SIGNATURE OF APPLICANT

9-2-20  
 \_\_\_\_\_  
 Date

  
 \_\_\_\_\_  
 SIGNATURE OF PROPERTY OWNER AUTHORIZING THE WORK

9-1-20  
 \_\_\_\_\_  
 Date



\*\*\*\*\*TO BE FILLED OUT BY CITY STAFF\*\*\*\*\*

Date Received: \_\_\_\_\_ Received By: \_\_\_\_\_

Project Eligible for Expedited Process:  Yes  No

Action Taken by Historic Preservation Officer:  Approved  Denied

Approved with the following Modifications: \_\_\_\_\_

\_\_\_\_\_  
\_\_\_\_\_

\_\_\_\_\_  
**SIGNATURE OF HISTORIC PRESERVATION OFFICER**

\_\_\_\_\_  
**DATE**

Date Considered by Historic Preservation Commission (if required): \_\_\_\_\_

Approved  Denied

Approved with the following Modifications: \_\_\_\_\_

\_\_\_\_\_  
\_\_\_\_\_

Historic Preservation Commission Decision Appealed by Applicant:  Yes  No

Date Appeal Considered by Planning & Zoning Commission (if required): \_\_\_\_\_

Approved  Denied

Approved with the following Modifications: \_\_\_\_\_

\_\_\_\_\_  
\_\_\_\_\_

Planning & Zoning Commission Decision Appealed by Applicant:  Yes  No

Date Appeal Considered by City Council (if required): \_\_\_\_\_

Approved  Denied

Approved with the following Modifications: \_\_\_\_\_

\_\_\_\_\_  
\_\_\_\_\_

**Submit this application to City Hall at 511 Mercer St. /P.O. Box 384, Dripping Springs, TX 78620. Call City Hall at (512)858-4725 if you have questions regarding this application.**

Received on/by: \_\_\_\_\_

Project Number: \_\_\_\_\_ - \_\_\_\_\_  
Only filled out by staff

Date, initials



### BILLING CONTACT FORM

Project Name: Phase 1 Remodel for CP 290 LLC & Pig Pen BBQ

Project Address: 301 U.S. Highway 290 West, Dripping Springs, TX 78620

Project Applicant Name: Bill Warren & Dusty Dennis

#### Billing Contact Information

Name: CP 290 LLC (Dusty Dennis)

Mailing Address: 607 Loving Ct.

Southlake, Texas 76092

Email: ddennis@creedpartners.com Phone Number: 210.621.3288

Type of Project/Application (check all that apply):

- |  |  |
|--|--|
| <input type="checkbox"/> Alternative Standard                      | <input type="checkbox"/> Special Exception     |
| <input checked="" type="checkbox"/> Certificate of Appropriateness | <input type="checkbox"/> Street Closure Permit |
| <input type="checkbox"/> Conditional Use Permit                    | <input type="checkbox"/> Subdivision           |
| <input type="checkbox"/> Development Agreement                     | <input type="checkbox"/> Waiver                |
| <input checked="" type="checkbox"/> Exterior Design                | <input type="checkbox"/> Wastewater Service    |
| <input type="checkbox"/> Landscape Plan                            | <input type="checkbox"/> Variance              |
| <input type="checkbox"/> Lighting Plan                             | <input type="checkbox"/> Zoning                |
| <input type="checkbox"/> Site Development Permit                   | <input type="checkbox"/> Other _____           |

*Applicants are required to pay all associated costs associated with a project's application for a permit, plan, certificate, special exception, waiver, variance, alternative standard, or agreement, regardless of City approval. Associated costs may include, but are not limited to, public notices and outside professional services provided to the City by engineers, attorneys, surveyors, inspectors, landscape consultants, lighting consultants, architects, historic preservation consultants, and others, as required. Associated costs will be billed at cost plus 20% to cover the City's additional administrative costs. Please see the online Master Fee Schedule for more details. By signing below, I am acknowledging that the above listed party is financially accountable for the payment and responsibility of these fees.*

  
Signature of Applicant

9-1-20  
Date



**A Restaurant Remodel for**

---

# **CP 290 LLC & Pig Pen BBQ**

---

**301 U.S. Highway 290 West  
Dripping Springs, Texas 78620**

*Herron Design Studio*

a r c h i t e c t u r e

101 Hays Street, Suite 409  
Dripping Springs, Texas 78620  
512.858.9889







Item 3.



**Site Photos**

**An Restaurant Remodel for  
CP 290 LLC & Pig Pen BBQ  
Phase 1 - Screened Cooking Porch  
301 U.S. Highway 290 West  
Dripping Springs, Texas 78620**







Item 3.

### Site Photos



**An Restaurant Remodel for  
CP 290 LLC & Pig Pen BBQ  
Phase 1 - Screened Cooking Porch  
301 U.S. Highway 290 West  
Dripping Springs, Texas 78620**



SQUARE FOOTAGES	
MAIN BLDG. HEATED AREA	2738 SQ. FT.
MAIN BLDG. WH CLOS & STORAGE AREAS	71 SQ. FT.
MAIN BLDG. FRONT COVERED PORCH	12 SQ. FT.
COVERED PORCH AREA	549 SQ. FT.
OUTBLDG. 1 HEATED AREA	306 SQ. FT.
OUTBLDG. 2 COVERED AREA	130 SQ. FT.
OUTBLDG. 3 COVERED AREA	76 SQ. FT.
OUTBLDG. 4 COVERED AREA	49 SQ. FT.
TOTAL PROJECT COVERED AREA	3922 SQ. FT.

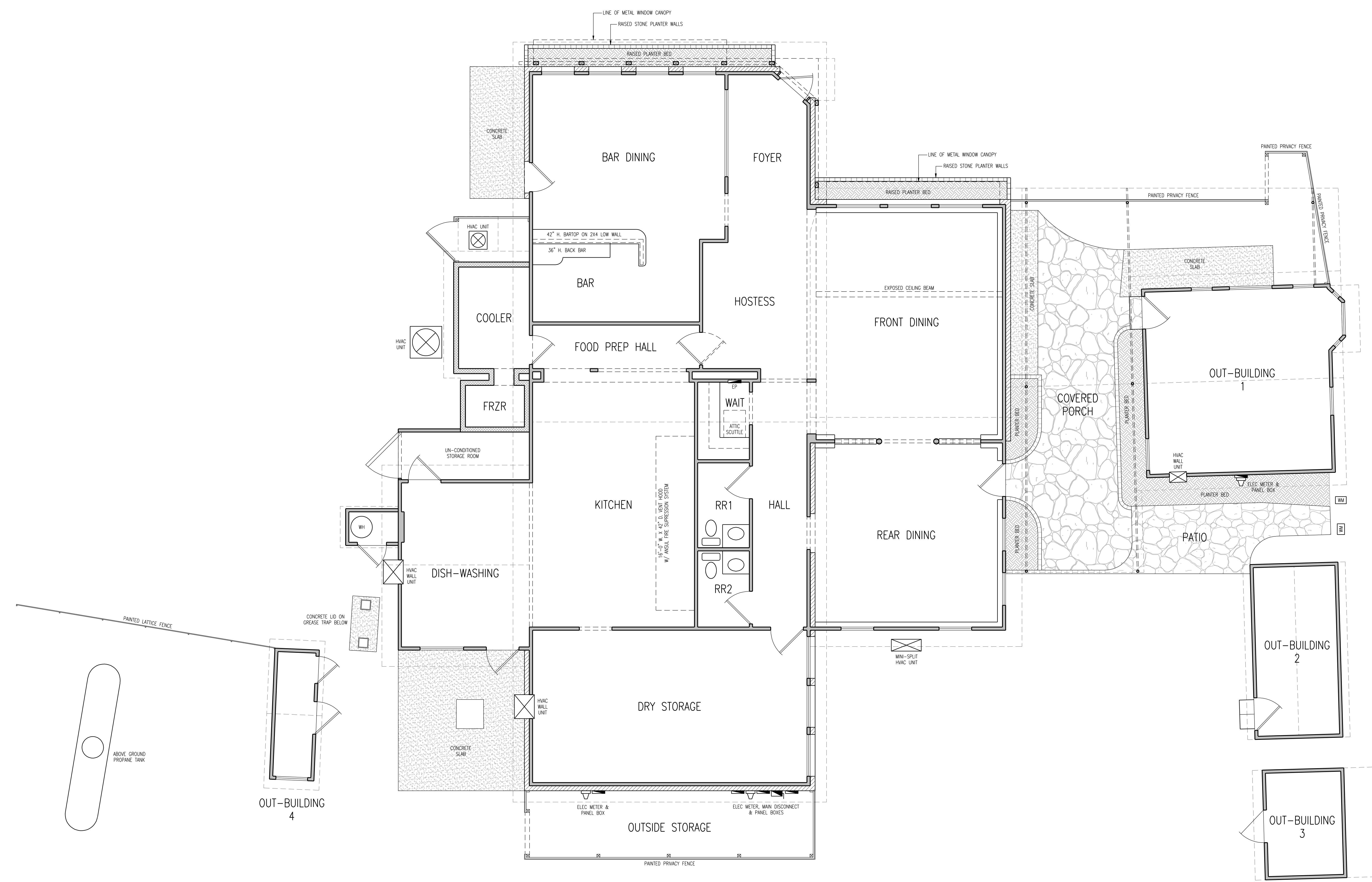

EXISTING FLOOR PLANS  
SCALE: 1/4" = 1'-0"

A Restaurant Remodel for CP 290 LLC & Pig Pen BBQ  
301 U.S. Highway 290 West  
Dripping Springs, Texas 78620



**Hennon Design Studio**  
architects  
101 Hays Street, Suite 409  
Dripping Springs, Texas 78620  
512.858.9889

REVISIONS

CRE2016  
AUG. 31, 2020  
**A1**



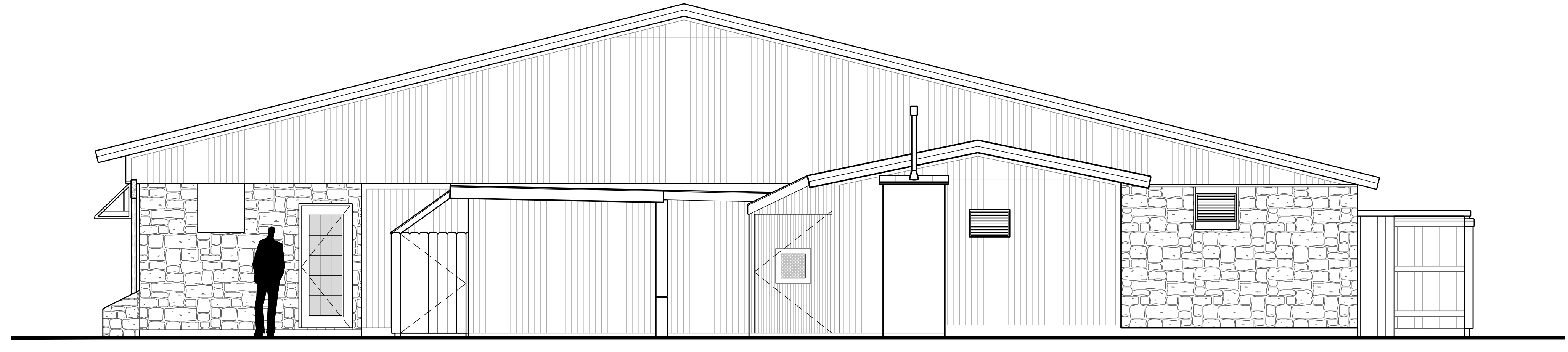

EXISTING RIGHT ELEVATION  
FACES WEST  
SCALE : 1/4" = 1'-0"

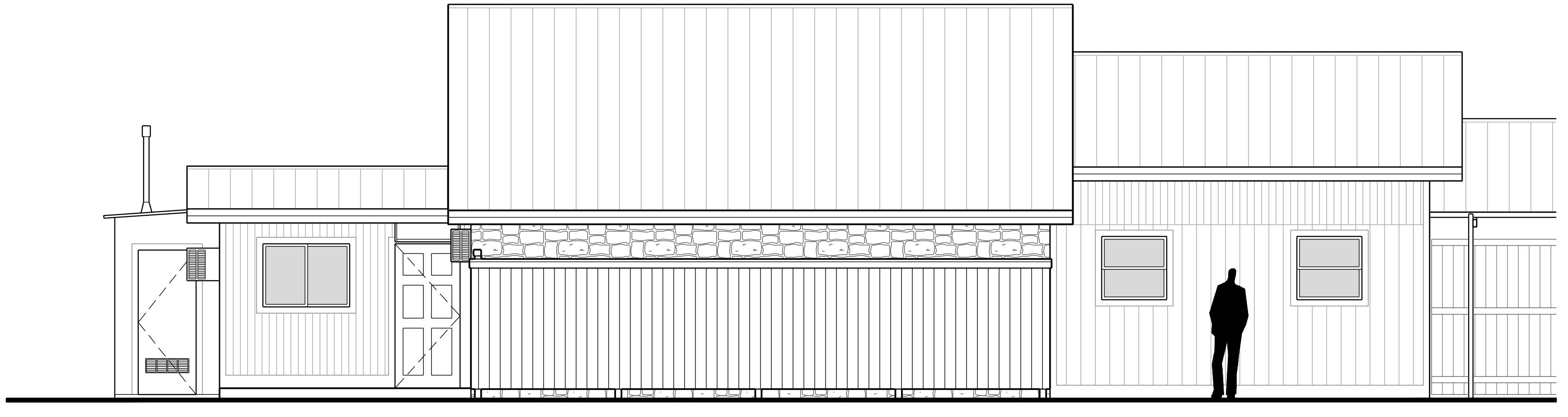

EXISTING REAR ELEVATION  
FACES SOUTH  
SCALE : 1/4" = 1'-0"

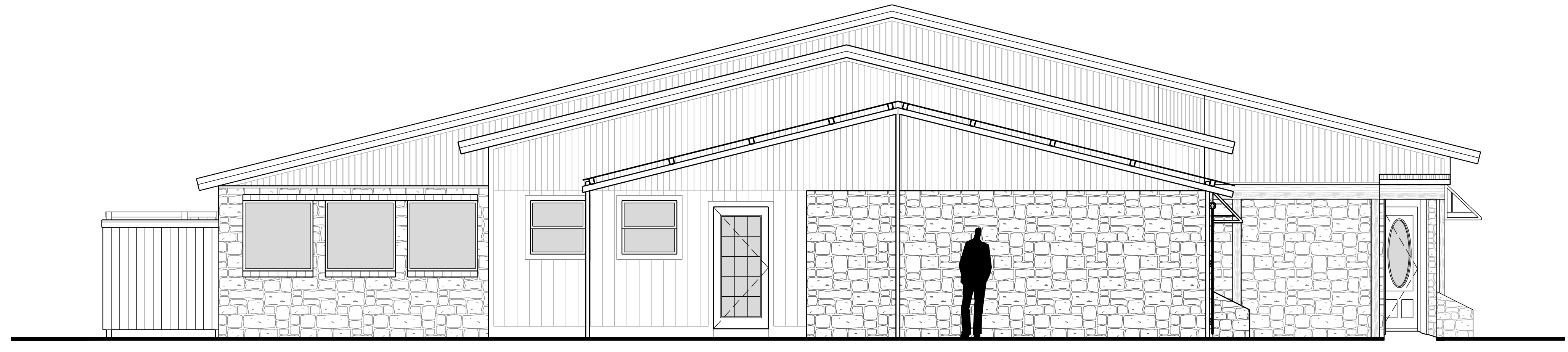

EXISTING LEFT ELEVATION  
FACES EAST  
SCALE : 1/4" = 1'-0"



EXISTING FRONT ELEVATION  
FACES NORTH  
SCALE : 1/4" = 1'-0"

A Restaurant Remodel for CP 290 LLC & Pig Pen BBQ  
301 U.S. Highway 290 West  
Dripping Springs, Texas 78620



*Hennon Design Studio*  
a r c h i t e c t u r e  
101 Hays Street, Suite 409  
Dripping Springs, Texas 78620  
512.858.9889

REVISIONS

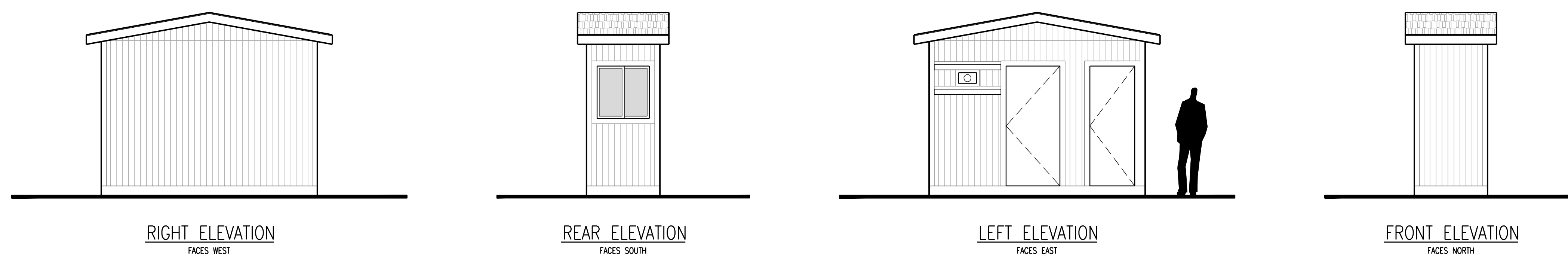

EXISTING OUT-BUILDING 4  
SCALE: 1/4" = 1'-0"

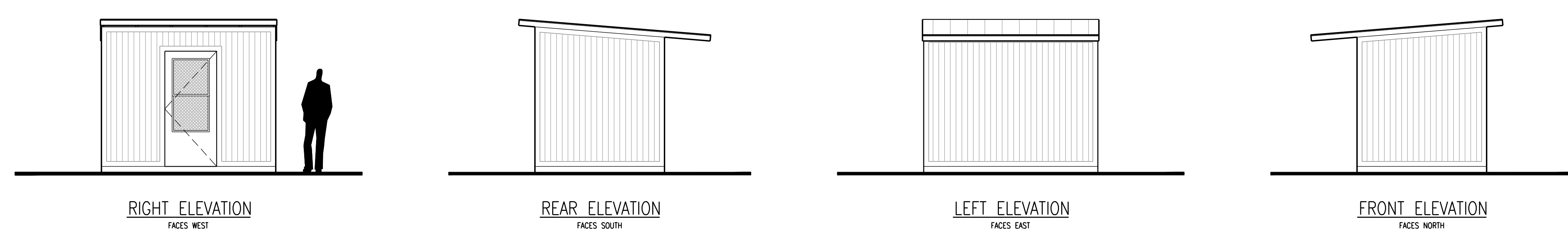

EXISTING OUT-BUILDING 3  
SCALE: 1/4" = 1'-0"

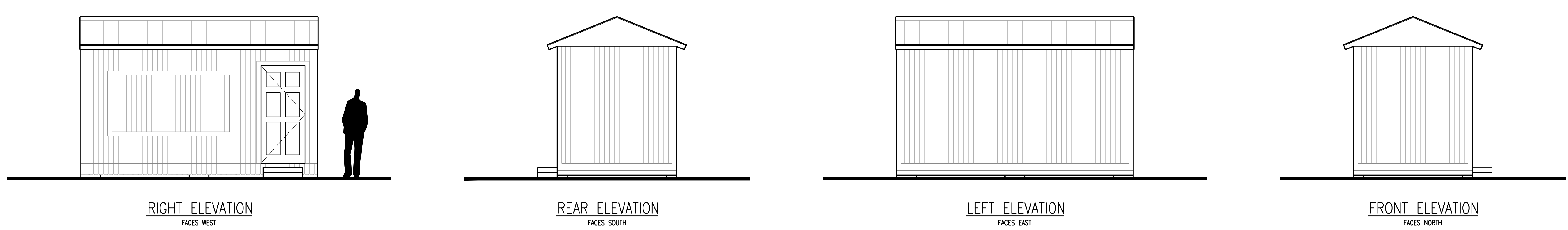

EXISTING OUT-BUILDING 2  
SCALE: 1/4" = 1'-0"

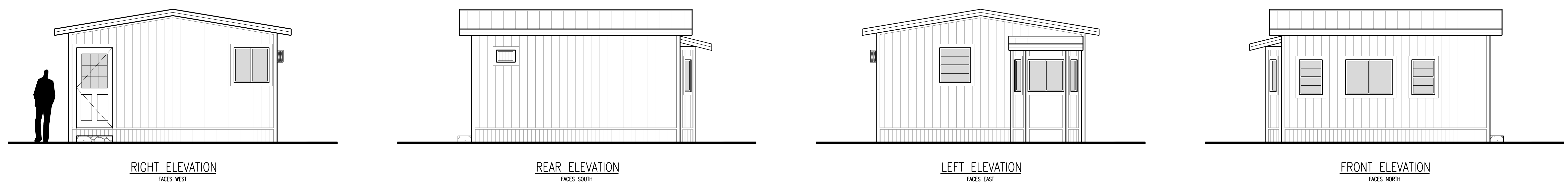

EXISTING OUT-BUILDING 1  
SCALE: 1/4" = 1'-0"

A Restaurant Remodel for CP 290 LLC & Pig Pen BBQ  
301 U.S. Highway 290 West  
Dripping Springs, Texas 78620



**Hennon Design Studio**  
a r c h i t e c t u r e  
101 Hays Street, Suite 409  
Dripping Springs, Texas 78620  
512.858.9889

REVISIONS



SQUARE FOOTAGES	
MAIN BLDG. HEATED AREA	2738 SQ. FT.
MAIN BLDG. WH CLOS. & STORAGE AREAS	71 SQ. FT.
MAIN BLDG. FRONT COVERED PORCH	12 SQ. FT.
COVERED PORCH AREA	540 SQ. FT.
OUTBLDG. 1 HEATED AREA	306 SQ. FT.
OUTBLDG. 2 COVERED AREA	130 SQ. FT.
OUTBLDG. 3 COVERED AREA	76 SQ. FT.
OUTBLDG. 4 COVERED AREA	49 SQ. FT.
TOTAL PROJECT COVERED AREA	3922 SQ. FT.

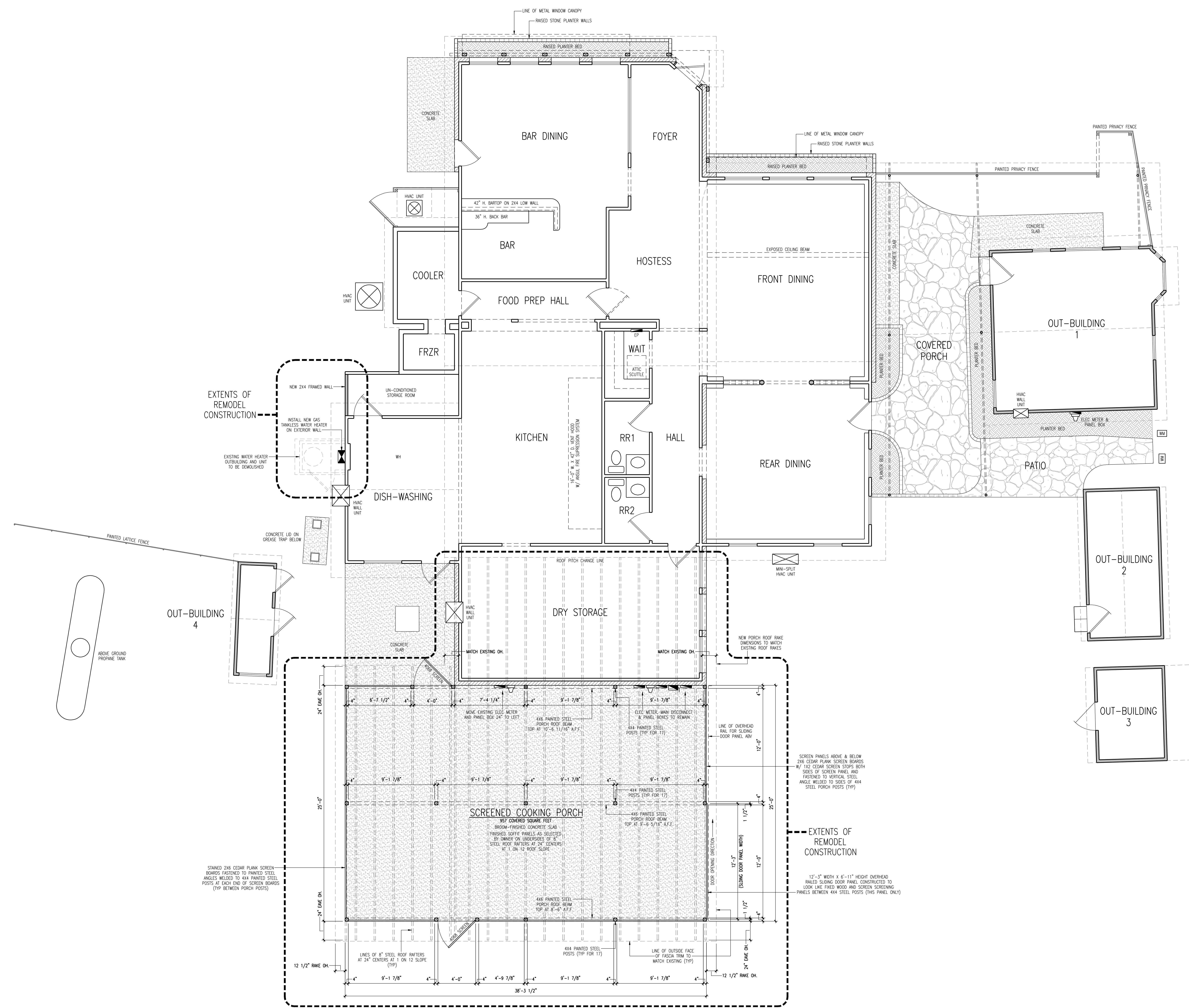

A Restaurant Remodel for CP 290 LLC & Pig Pen BBQ  
 301 U.S. Highway 290 West  
 Dripping Springs, Texas 78620



**Hennon Design Studio**  
 a r c h i t e c t u r e  
 101 Hays Street, Suite 409  
 Dripping Springs, Texas 78620  
 512.856.9899

REVISIONS

CRE2016  
 AUG. 31, 2020  
**A4**

REMODEL FLOOR PLAN  
 SCALE: 1/4" = 1'-0"



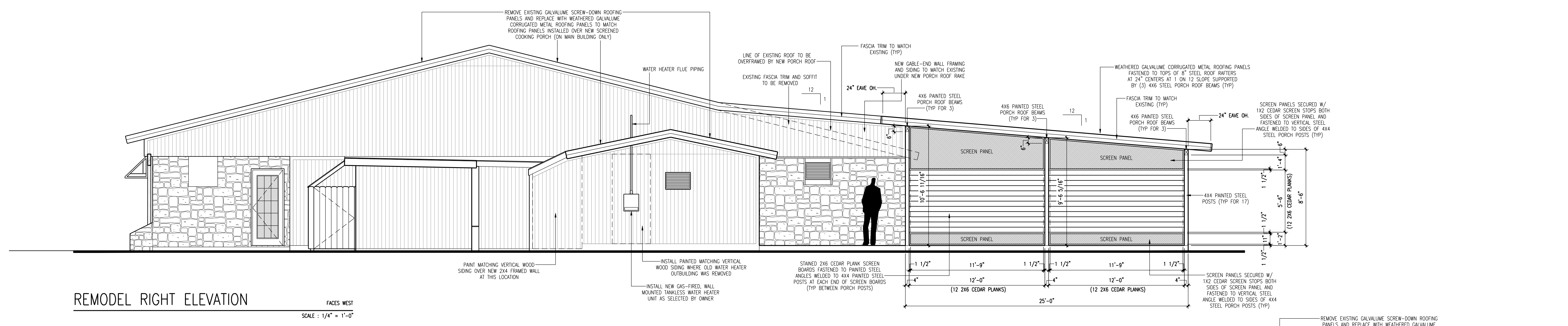

REVISIONS

REMODEL RIGHT ELEVATION  
FACES WEST  
SCALE: 1/4" = 1'-0"

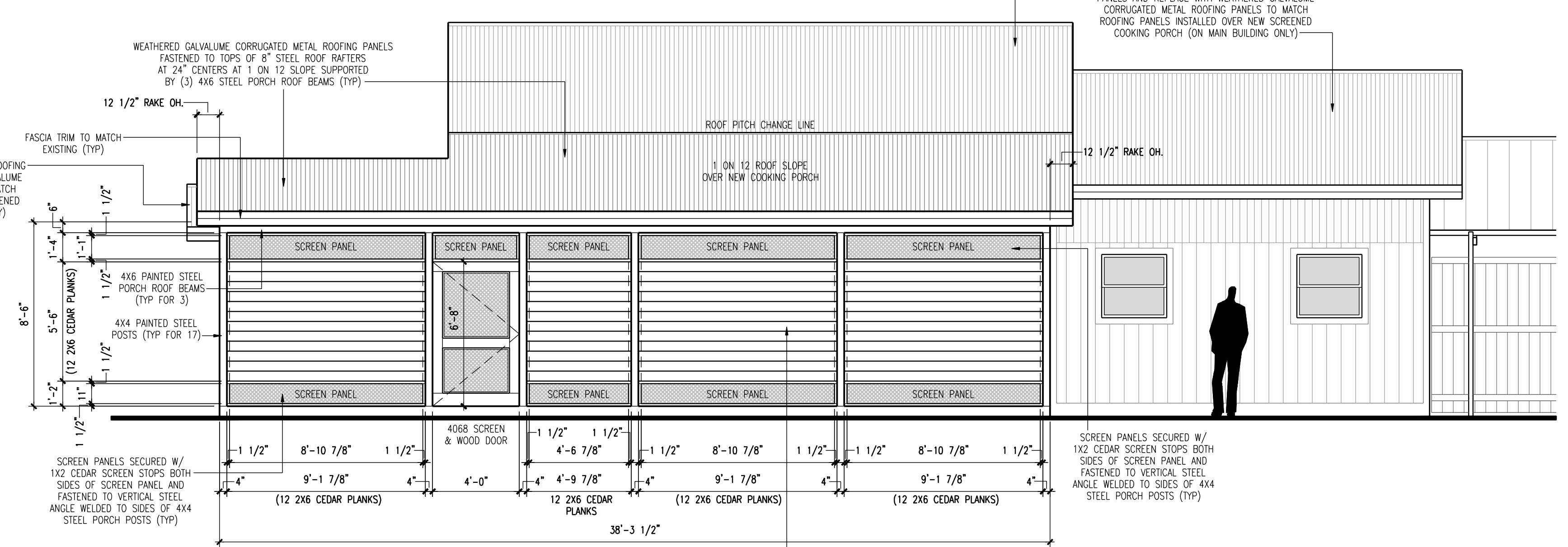

REMODEL REAR ELEVATION  
FACES SOUTH  
SCALE: 1/4" = 1'-0"

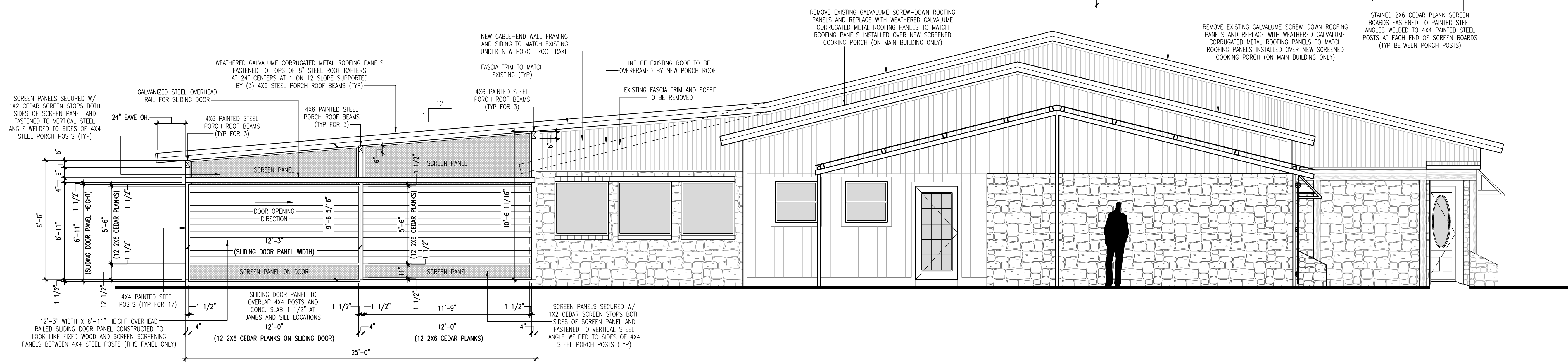

REMODEL LEFT ELEVATION  
FACES EAST  
SCALE: 1/4" = 1'-0"

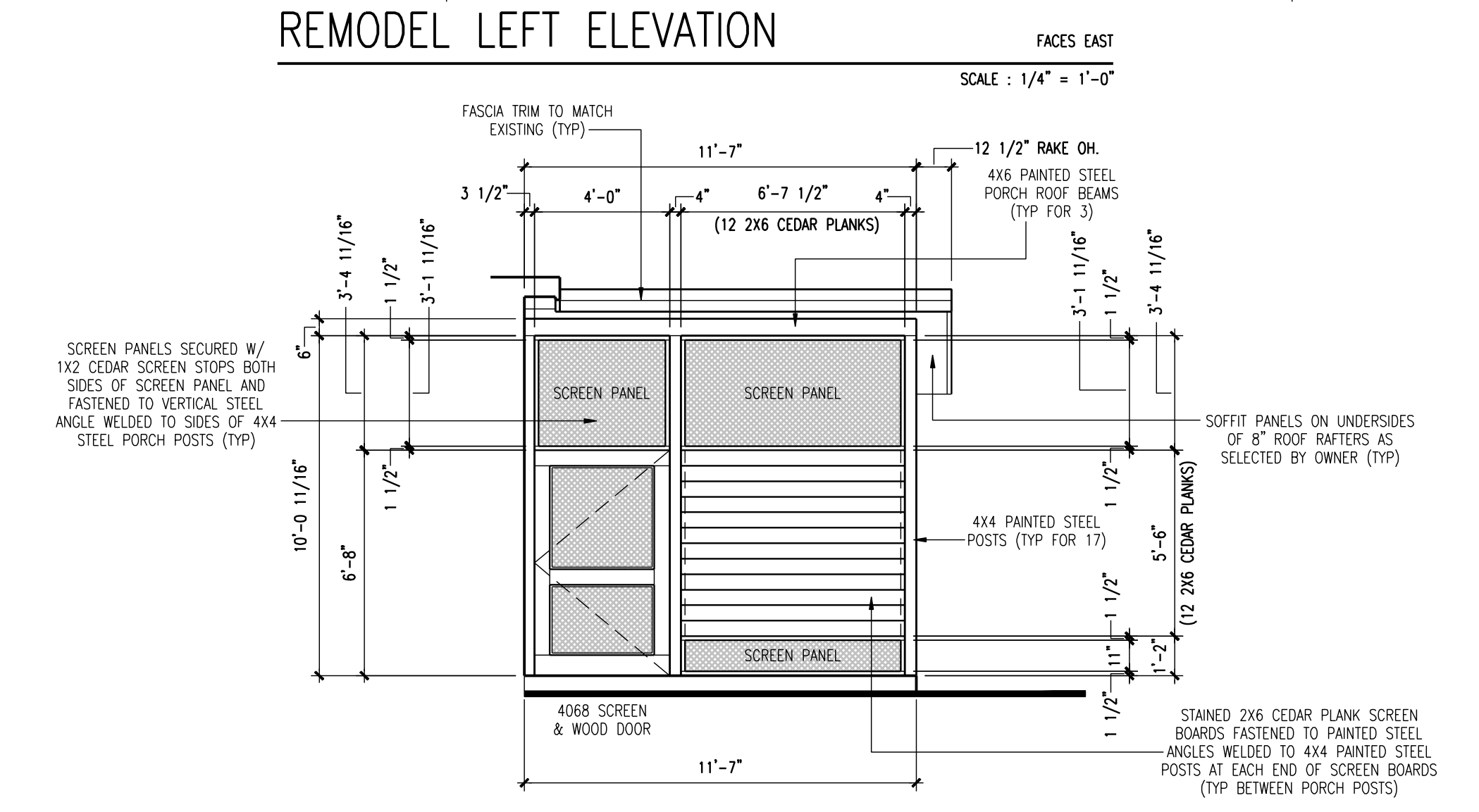

SCREENED COOKING PORCH FRONT ELEVATION  
FACES NORTH  
SCALE: 1/4" = 1'-0"



REMODEL FRONT ELEVATION  
FACES NORTH  
SCALE: 1/4" = 1'-0"



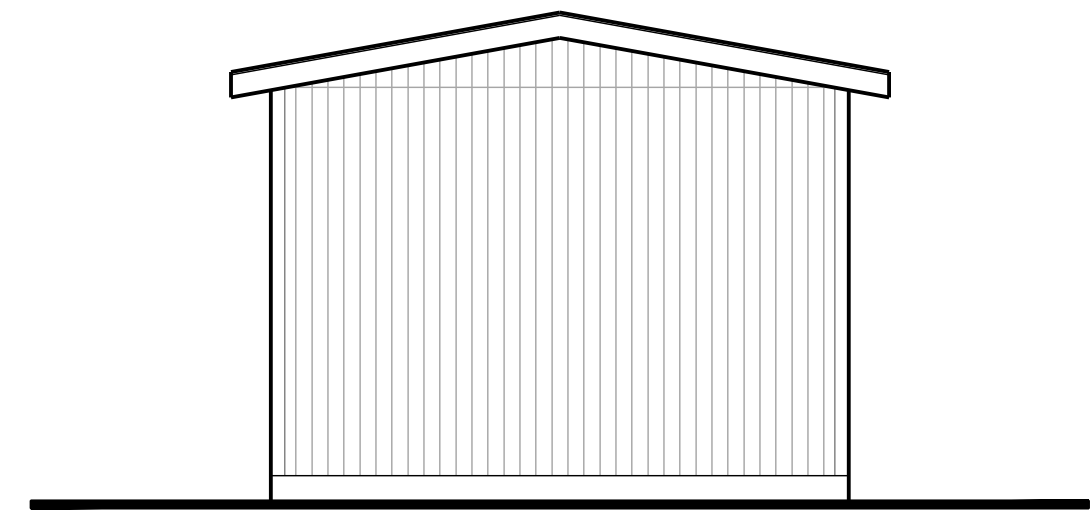

RIGHT ELEVATION  
FACES WEST

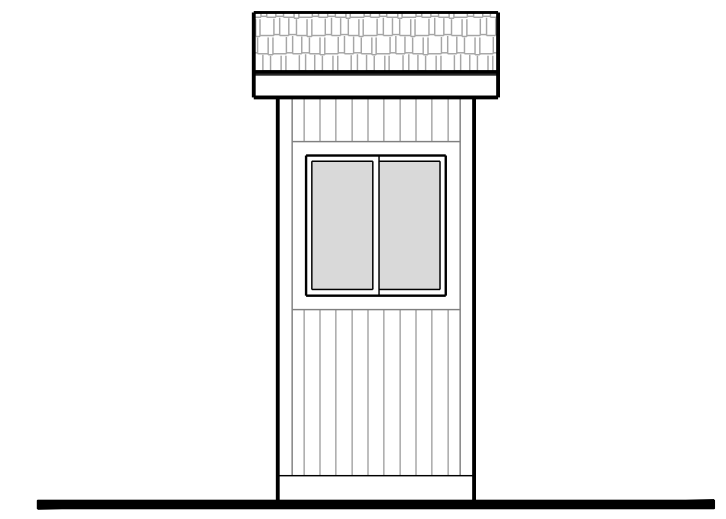

REAR ELEVATION  
FACES SOUTH

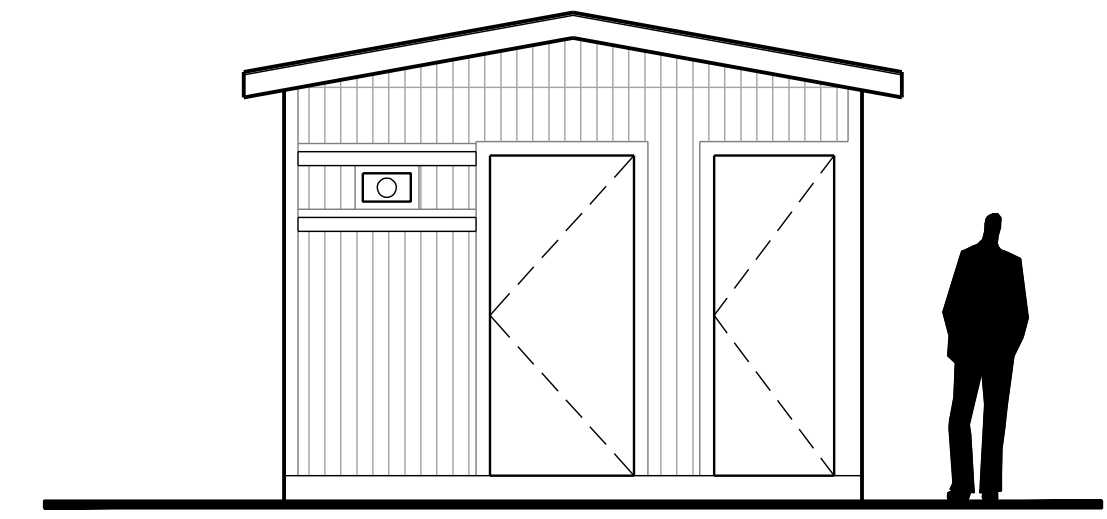

LEFT ELEVATION  
FACES EAST

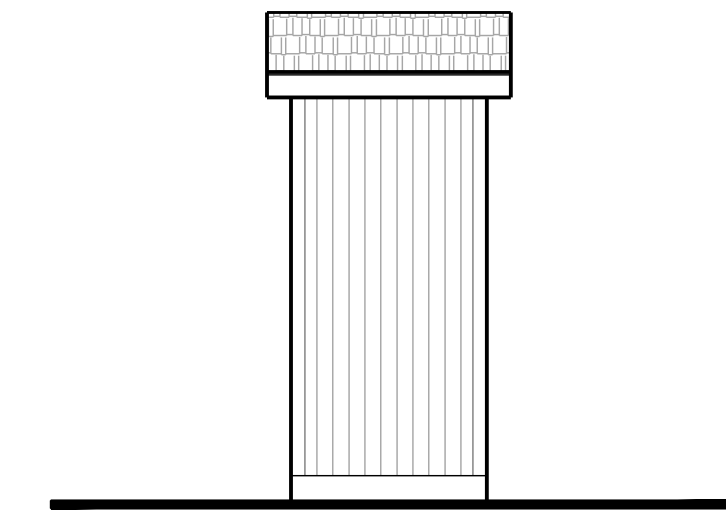

FRONT ELEVATION  
FACES NORTH

REMODEL OUT-BUILDING 4

SCALE : 1/4" = 1'-0"

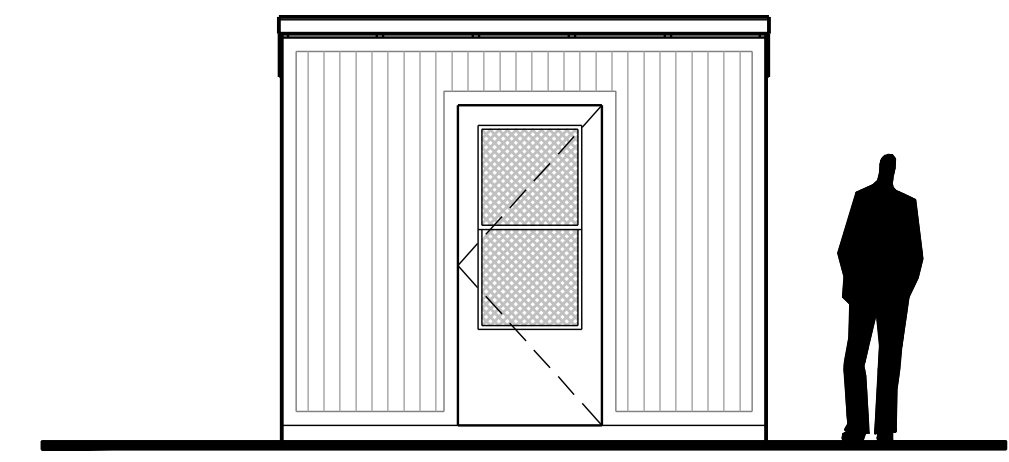

RIGHT ELEVATION  
FACES WEST

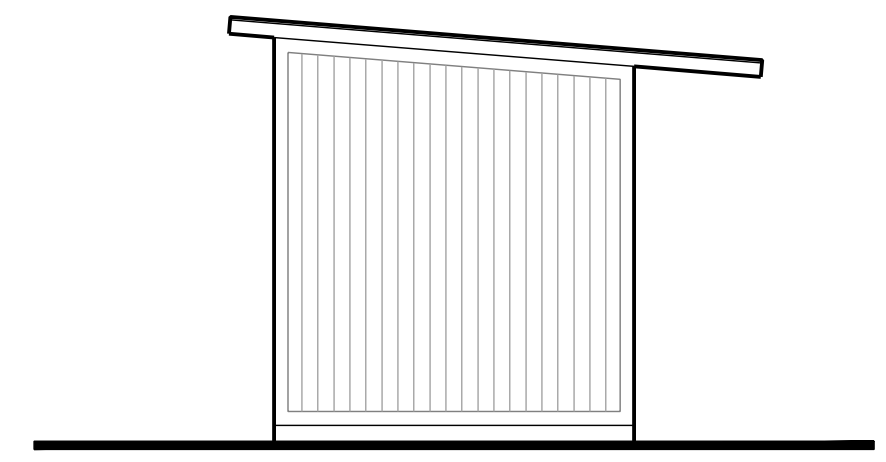

REAR ELEVATION  
FACES SOUTH

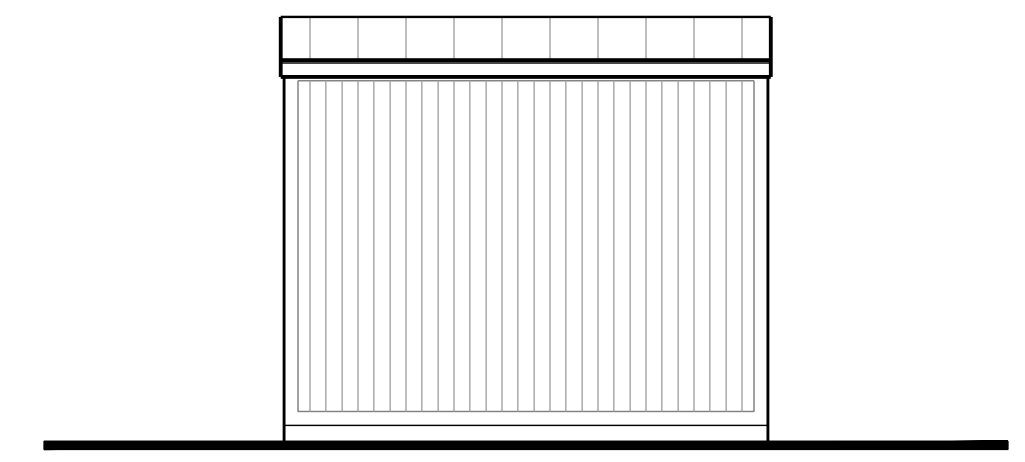

LEFT ELEVATION  
FACES EAST

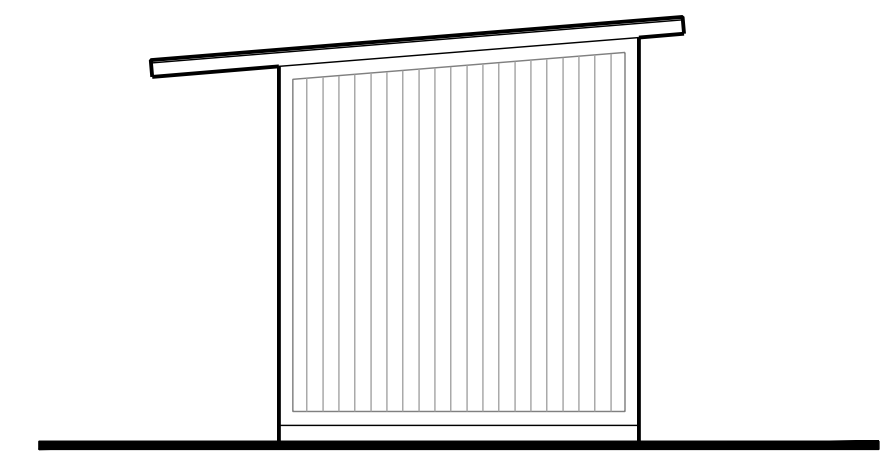

FRONT ELEVATION  
FACES NORTH

REMODEL OUT-BUILDING 3

SCALE : 1/4" = 1'-0"

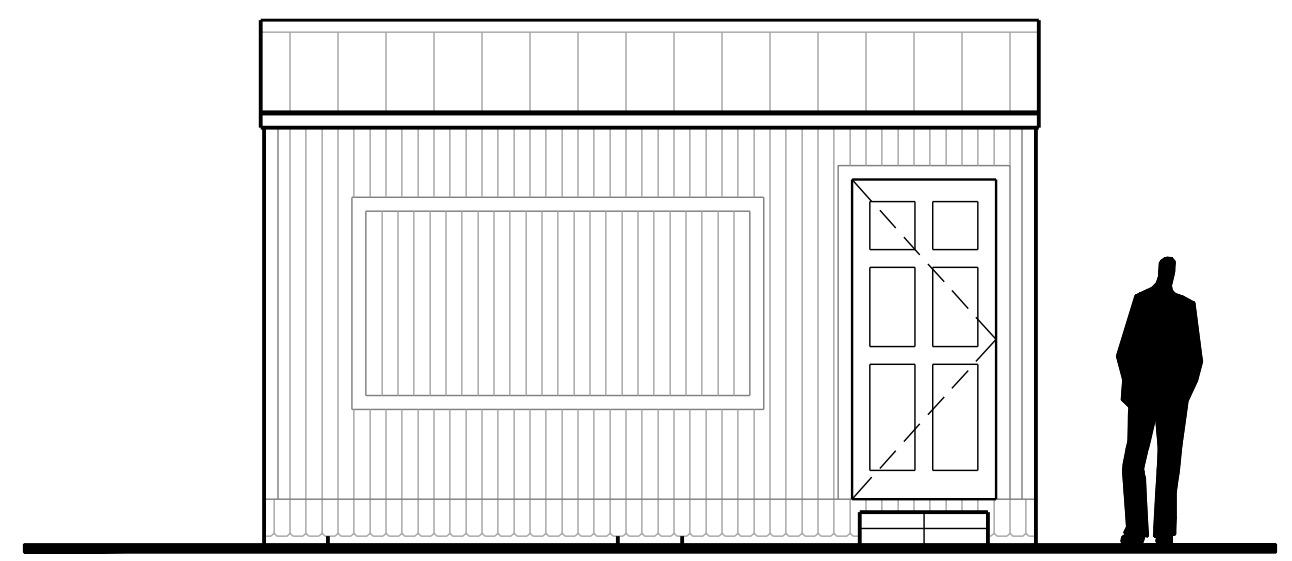

RIGHT ELEVATION  
FACES WEST

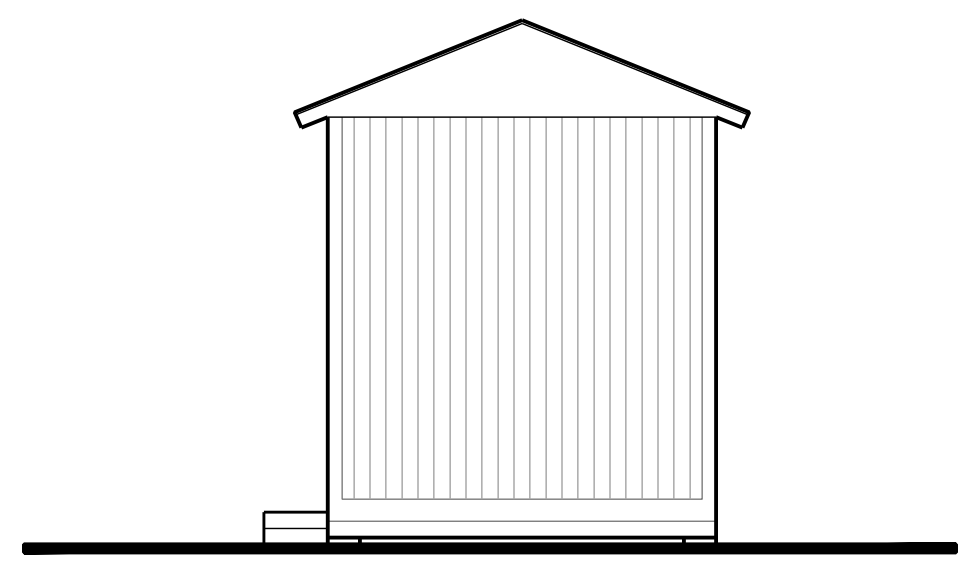

REAR ELEVATION  
FACES SOUTH

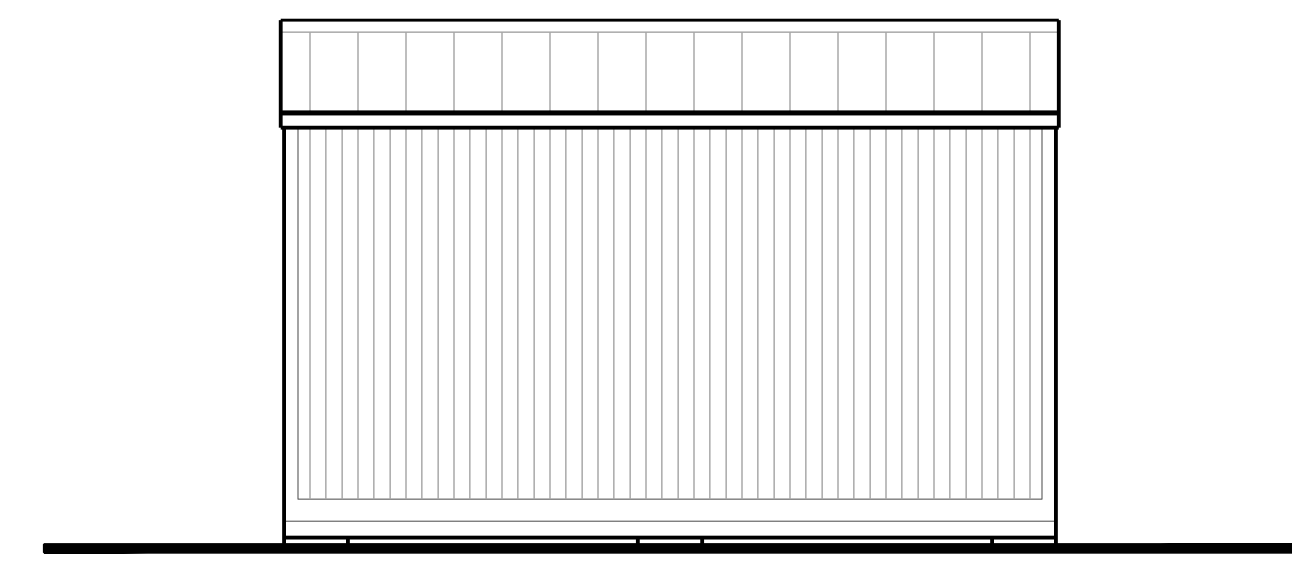

LEFT ELEVATION  
FACES EAST

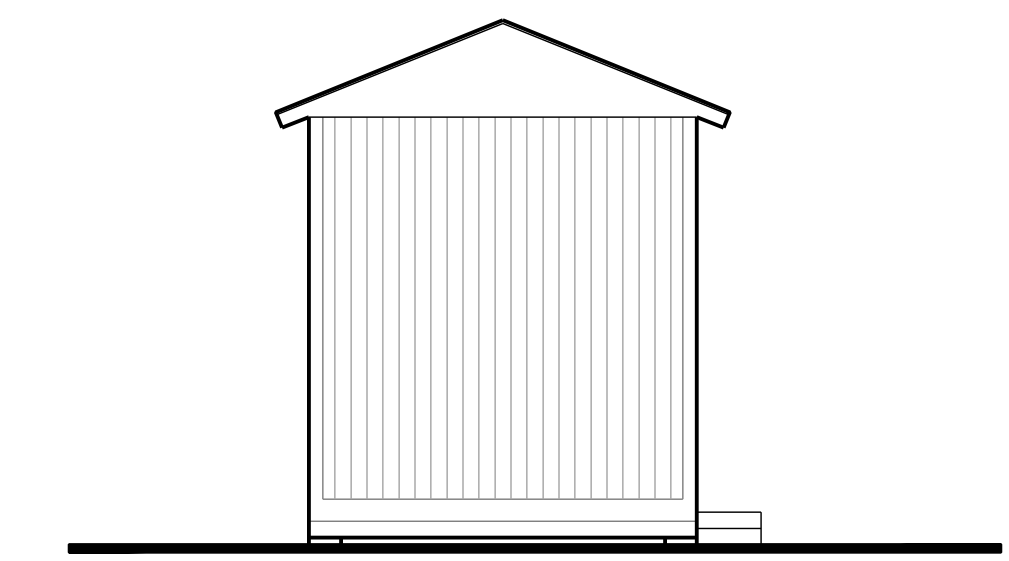

FRONT ELEVATION  
FACES NORTH

REMODEL OUT-BUILDING 2

SCALE : 1/4" = 1'-0"

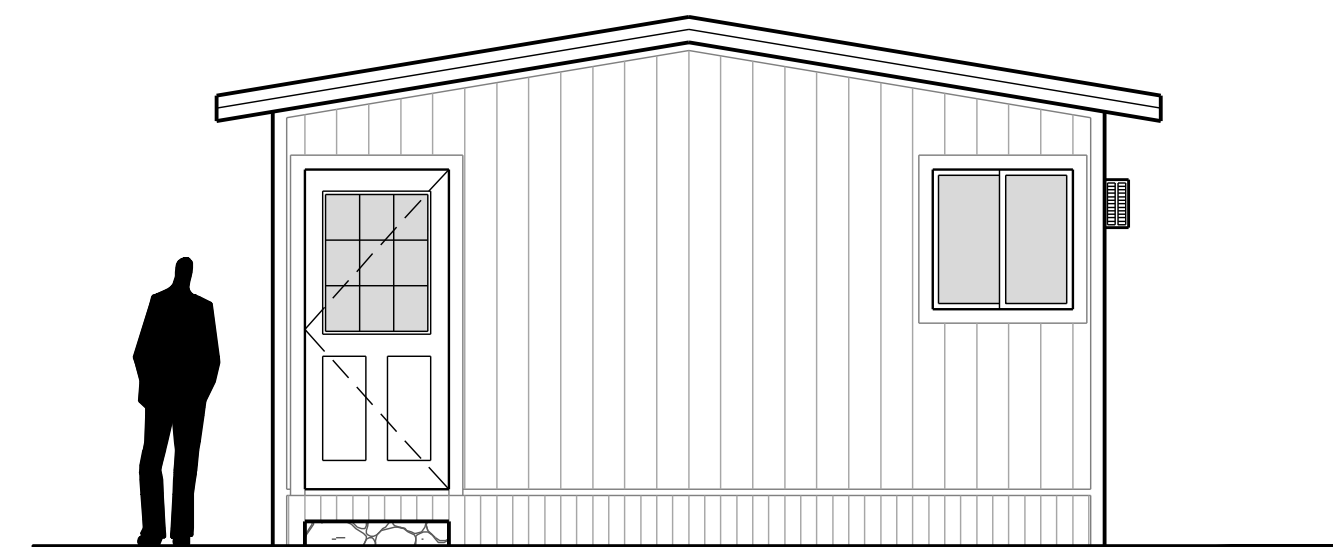

RIGHT ELEVATION  
FACES WEST

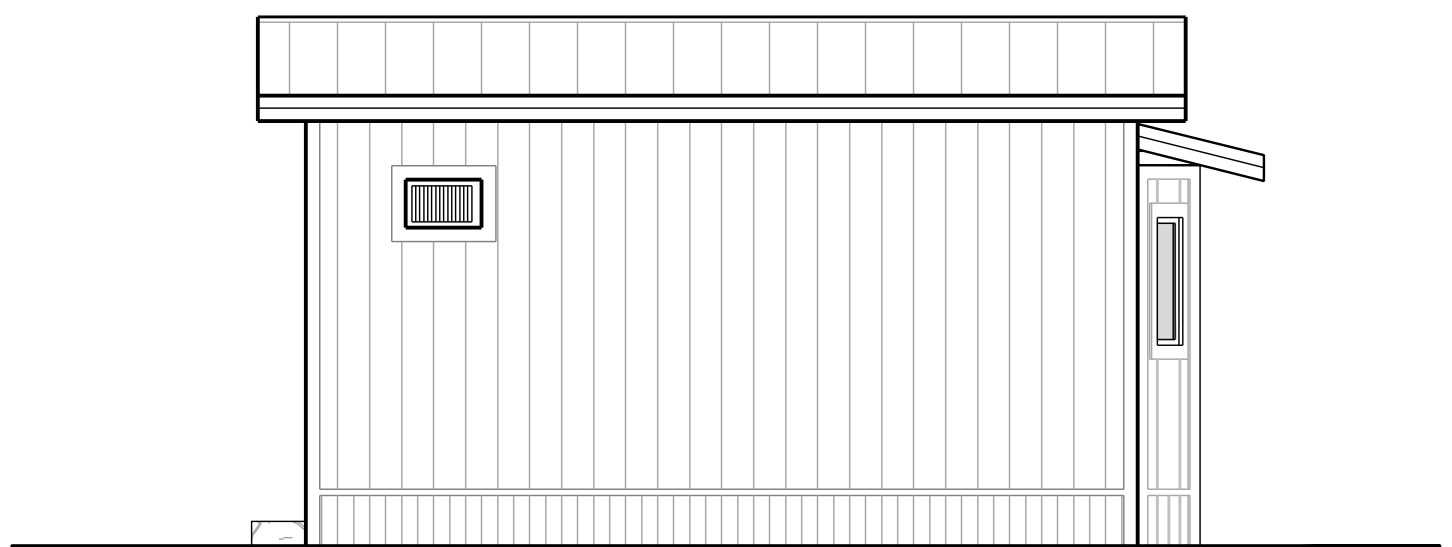

REAR ELEVATION  
FACES SOUTH

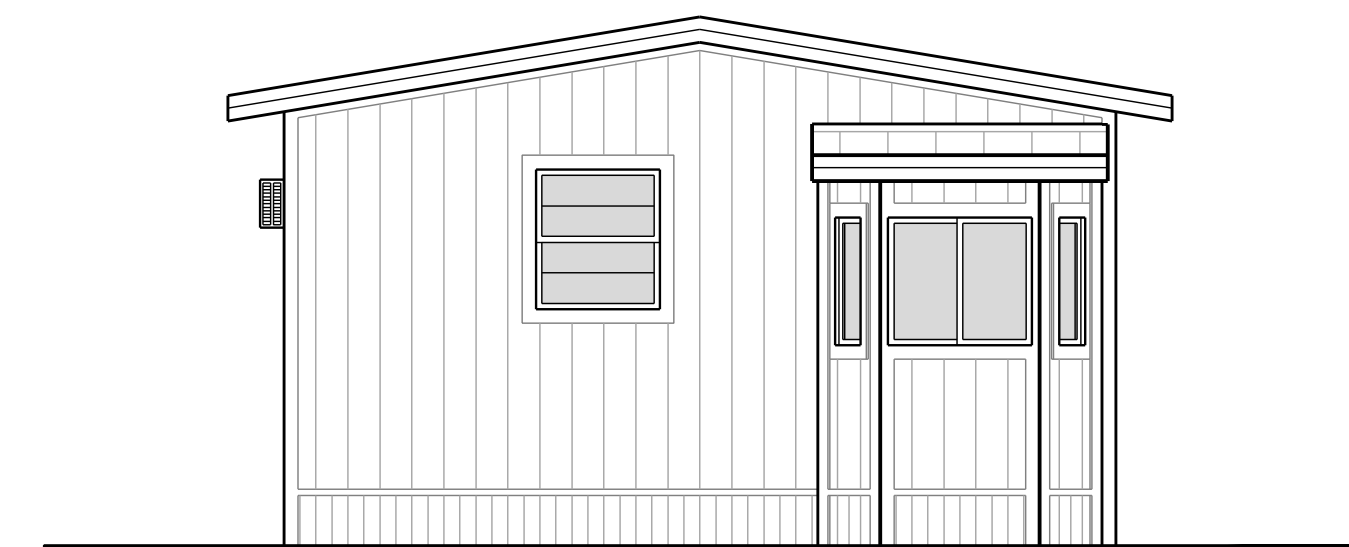

LEFT ELEVATION  
FACES EAST

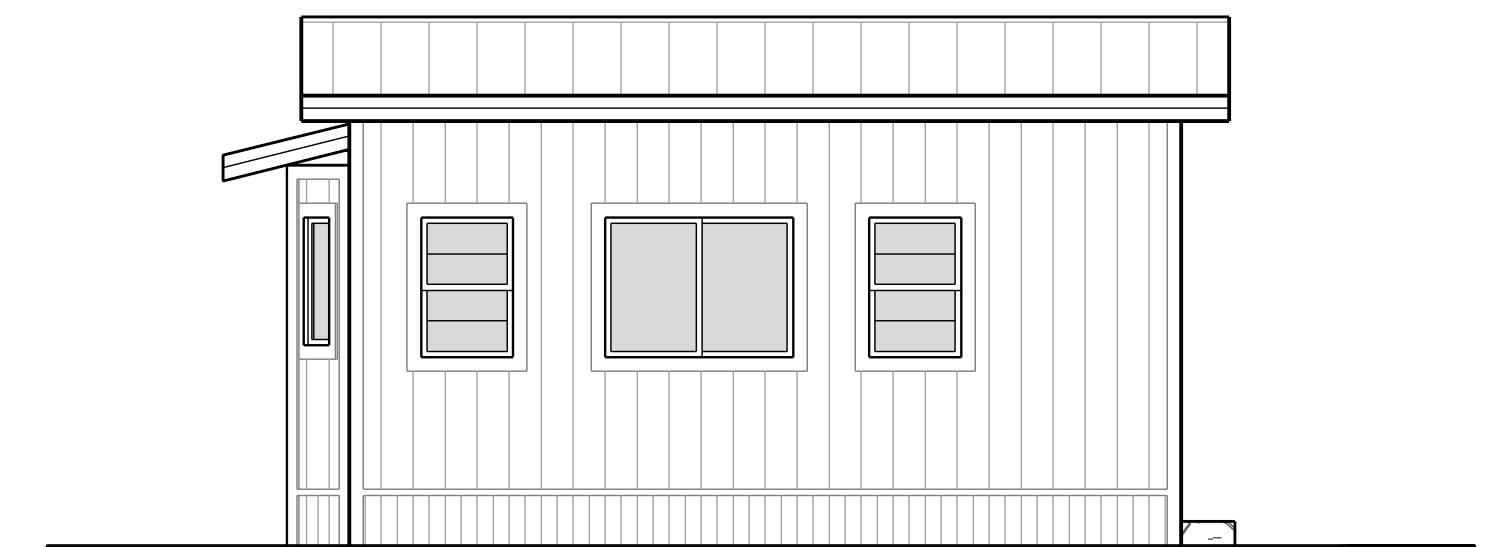

FRONT ELEVATION  
FACES NORTH

REMODEL OUT-BUILDING 1

SCALE : 1/4" = 1'-0"

A Restaurant Remodel for CP 290 LLC & Pig Pen BBQ  
301 U.S. Highway 290 West  
Dripping Springs, Texas 78620

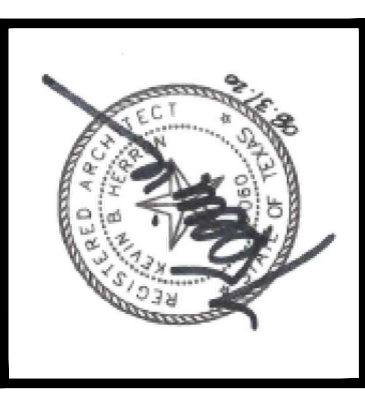

Hennon Design Studio  
architects  
101 Hays Street, Suite 409  
Dripping Springs, Texas 78620  
512.856.9889

REVISIONS

CRE2016  
AUG. 31, 2020  
**A6**





REMODEL REAR ELEVATION

FACES SOUTH



## Exterior Materials & Colors



Black Paint for Screened Cooking  
Porch Steel Posts, Beams & Rafters



Stained 2X6 S4S Cedar Plank Screen Panels  
installed between 4X4 Steel Porch Posts  
and 4X6 Steel Porch Beams  
(All Steel to be painted Black)

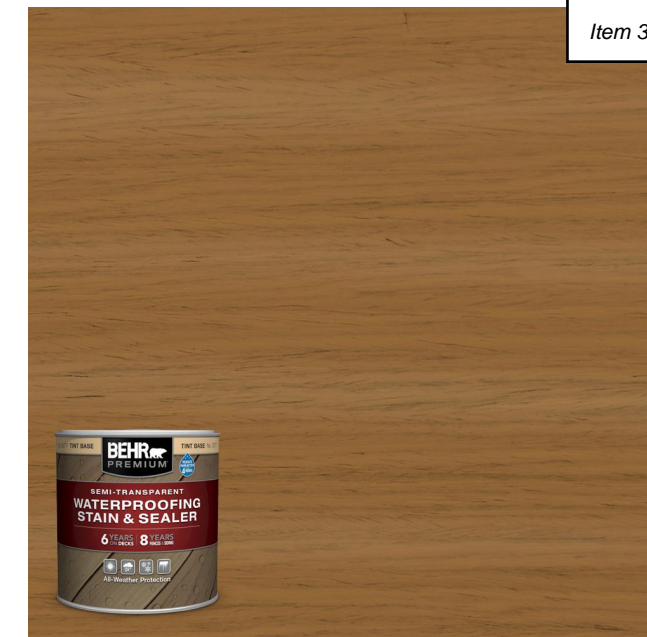

Wood Stain for Cedar Plank Screen  
Panels, Screen Door & Screen  
Panel Frames



48" wide x 80" tall Stained  
Cedar Screen Door

**An Restaurant Remodel for  
CP 290 LLC & Pig Pen BBQ  
Phase 1 - Screened Cooking Porch  
301 U.S. Highway 290 West  
Dripping Springs, Texas 78620**

**Herron Design Studio, architecture  
101 Hays Street, Suite 409  
Dripping Springs, Texas 78620  
512.858.9889**



Pre-weathered Galvalume Corrugated  
Metal Roofing Panels on New Screened  
Cooking Porch and to be installed on  
Roof of Main Building





**STAFF REPORT**  
**City of Dripping Springs**  
**PO Box 384**  
**511 Mercer Street**  
**Dripping Springs, TX 78602**

---

**Submitted By:** Andrea Cunningham, City Secretary

---

**Commission Meeting Date:** October 1, 2020

**Agenda Item Wording:** **Discuss and consider approval of the Historic Preservation Commission 2021 Annual Meeting Calendar.**

**Agenda Item Requestor:** Andrea Cunningham, City Secretary

---

**Summary/Background:** Annually the City prepares the meeting calendar for Boards, Commissions and Committees. The attached calendar for the Economic Development Committee considers the approved City of Dripping Springs Holiday Calendar and additional observed holidays by DSISD.

The Historic Preservation Commission meets the first Thursday of each month at 4:00 p.m. The attached calendar for the Historic Preservation Commission includes has no conflicts with City of Dripping Springs Holidays or DSISD holidays.

**Recommended Commission Actions:** Staff recommends approval of the attached calendar.

**Attachments:**

1. Approved City Hall Holiday Calendar
2. Proposed HPC 2021 Meeting Calendar

**Next Steps/Schedule:**

1. Prepare 2021 meeting calendar for review and approval by City Council.
2. Upon City Council approval meetings will be updated on the City website and calendar invites will be forwarded to Committee Members.



# 2021

## Holidays

### JANUARY

SUN	MON	TUE	WED	THU	FRI	SAT
					1	2
3	4	5	6	7	8	9
10	11	12	13	14	15	16
17	18	19	20	21	22	23
24	25	26	27	28	29	30
31						

### FEBRUARY

SUN	MON	TUE	WED	THU	FRI	SAT
	1	2	3	4	5	6
7	8	9	10	11	12	13
14	15	16	17	18	19	20
21	22	23	24	25	26	27
28						

### MARCH

SUN	MON	TUE	WED	THU	FRI	SAT
	1	2	3	4	5	6
7	8	9	10	11	12	13
14	15	16	17	18	19	20
21	22	23	24	25	26	27
28	29	30	31			

### APRIL

SUN	MON	TUE	WED	THU	FRI	SAT
				1	2	3
4	5	6	7	8	9	10
11	12	13	14	15	16	17
18	19	20	21	22	23	24
25	26	27	28	29	30	

### MAY

SUN	MON	TUE	WED	THU	FRI	SAT
						1
2	3	4	5	6	7	8
9	10	11	12	13	14	15
16	17	18	19	20	21	22
23	24	25	26	27	28	29
30	31					

### JUNE

SUN	MON	TUE	WED	THU	FRI	SAT
		1	2	3	4	5
6	7	8	9	10	11	12
13	14	15	16	17	18	19
20	21	22	23	24	25	26
27	28	29	30			

### JULY

SUN	MON	TUE	WED	THU	FRI	SAT
				1	2	3
4	5	6	7	8	9	10
11	12	13	14	15	16	17
18	19	20	21	22	23	24
25	26	27	28	29	30	31

### AUGUST

SUN	MON	TUE	WED	THU	FRI	SAT
1	2	3	4	5	6	7
8	9	10	11	12	13	14
15	16	17	18	19	20	21
22	23	24	25	26	27	28
29	30	31				

### SEPTEMBER

SUN	MON	TUE	WED	THU	FRI	SAT
			1	2	3	4
5	6	7	8	9	10	11
12	13	14	15	16	17	18
19	20	21	22	23	24	25
26	27	28	29	30		

### OCTOBER

SUN	MON	TUE	WED	THU	FRI	SAT
					1	2
3	4	5	6	7	8	9
10	11	12	13	14	15	16
17	18	19	20	21	22	23
24	25	26	27	28	29	30
31						

### NOVEMBER

SUN	MON	TUE	WED	THU	FRI	SAT
	1	2	3	4	5	6
7	8	9	10	11	12	13
14	15	16	17	18	19	20
21	22	23	24	25	26	27
28	29	30				

### DECEMBER

SUN	MON	TUE	WED	THU	FRI	SAT
			1	2	3	4
5	6	7	8	9	10	11
12	13	14	15	16	17	18
19	20	21	22	23	24	25
26	27	28	29	30	31	

### Holidays - City Hall Closures

- January 1 - New Year's Day
- January 18 - Martin Luther King Day
- February 15 - Presidents Day
- May 31 - Memorial Day
- July 5 - Independence Day (observed)
- September 6 - Labor Day
- October 11 - Columbus Day
- November 11 - Veterans Day
- November 25 & 26 - Thanksgiving Day
- December 24 - Christmas Eve
- December 31 - New Year's Eve

### DSISD Holidays & Breaks

- Spring Break, March 15 - 19
- April 2 - Staff/Student Holiday
- Thanksgiving Break, November 23 - 26
- Winter Break, December 20 - January 4



# 2021

## Historic Preservation Commission

### City Hall Closure, DSISD Break

#### JANUARY

SUN	MON	TUE	WED	THU	FRI	SAT
					1	2
3	4	5	6	7	8	9
10	11	12	13	14	15	16
17	18	19	20	21	22	23
24	25	26	27	28	29	30
31						

#### FEBRUARY

SUN	MON	TUE	WED	THU	FRI	SAT
	1	2	3	4	5	6
7	8	9	10	11	12	13
14	15	16	17	18	19	20
21	22	23	24	25	26	27
28						

#### MARCH

SUN	MON	TUE	WED	THU	FRI	SAT
	1	2	3	4	5	6
7	8	9	10	11	12	13
14	15	16	17	18	19	20
21	22	23	24	25	26	27
28	29	30	31			

#### APRIL

SUN	MON	TUE	WED	THU	FRI	SAT
				1	2	3
4	5	6	7	8	9	10
11	12	13	14	15	16	17
18	19	20	21	22	23	24
25	26	27	28	29	30	

#### MAY

SUN	MON	TUE	WED	THU	FRI	SAT
						1
2	3	4	5	6	7	8
9	10	11	12	13	14	15
16	17	18	19	20	21	22
23	24	25	26	27	28	29
30	31					

#### JUNE

SUN	MON	TUE	WED	THU	FRI	SAT
		1	2	3	4	5
6	7	8	9	10	11	12
13	14	15	16	17	18	19
20	21	22	23	24	25	26
27	28	29	30			

#### JULY

SUN	MON	TUE	WED	THU	FRI	SAT
				1	2	3
4	5	6	7	8	9	10
11	12	13	14	15	16	17
18	19	20	21	22	23	24
25	26	27	28	29	30	31

#### AUGUST

SUN	MON	TUE	WED	THU	FRI	SAT
1	2	3	4	5	6	7
8	9	10	11	12	13	14
15	16	17	18	19	20	21
22	23	24	25	26	27	28
29	30	31				

#### SEPTEMBER

SUN	MON	TUE	WED	THU	FRI	SAT
			1	2	3	4
5	6	7	8	9	10	11
12	13	14	15	16	17	18
19	20	21	22	23	24	25
26	27	28	29	30		

#### OCTOBER

SUN	MON	TUE	WED	THU	FRI	SAT
						1 2
3	4	5	6	7	8	9
10	11	12	13	14	15	16
17	18	19	20	21	22	23
24	25	26	27	28	29	30
31						

#### NOVEMBER

SUN	MON	TUE	WED	THU	FRI	SAT
	1	2	3	4	5	6
7	8	9	10	11	12	13
14	15	16	17	18	19	20
21	22	23	24	25	26	27
28	29	30				

#### DECEMBER

SUN	MON	TUE	WED	THU	FRI	SAT
			1	2	3	4
5	6	7	8	9	10	11
12	13	14	15	16	17	18
19	20	21	22	23	24	25
26	27	28	29	30	31	

January  
7 - HPC @ 4:00 p.m.

February  
4 - HPC @ 4:00 p.m.

March  
4 - HPC @ 4:00 p.m.

April  
1 - HPC @ 4:00 p.m.

May  
6 - HPC @ 4:00 p.m.

June  
3 - HPC @ 4:00 p.m.

July  
1 - HPC @ 4:00 p.m.

August  
5 - HPC @ 4:00 p.m.

September  
2 - HPC @ 4:00 p.m.

October  
7 - HPC @ 4:00 p.m.

November  
4 - HPC @ 4:00 p.m.

December  
2 - HPC @ 4:00 p.m.



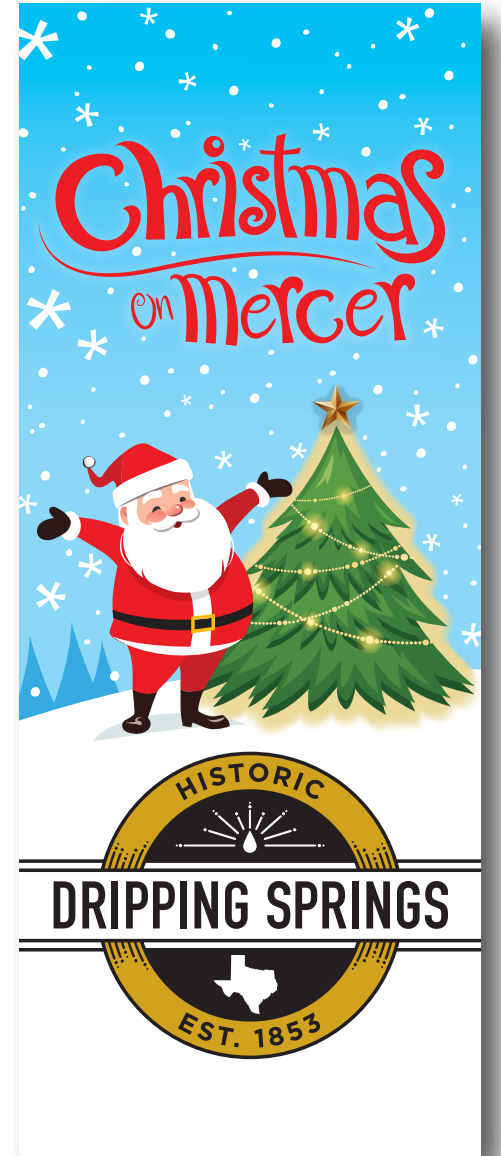
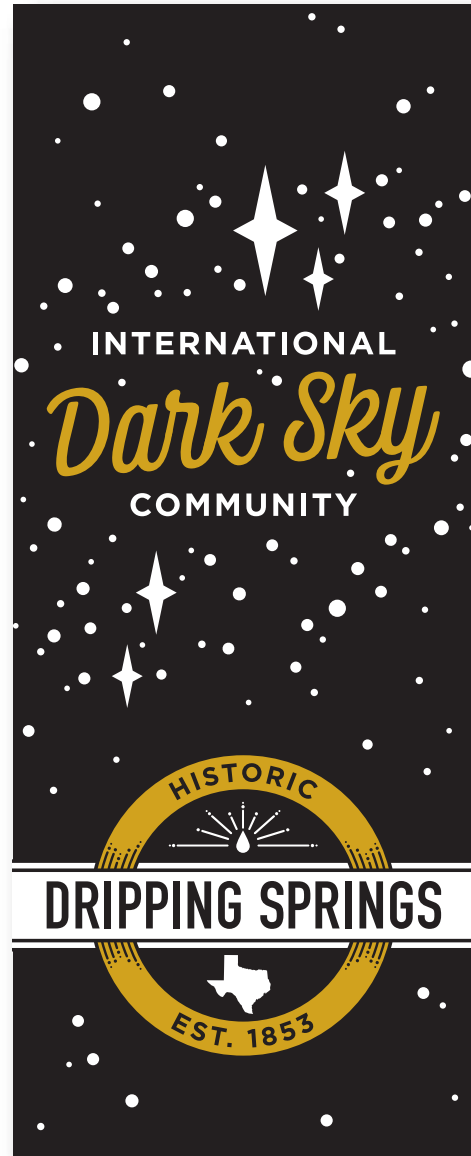
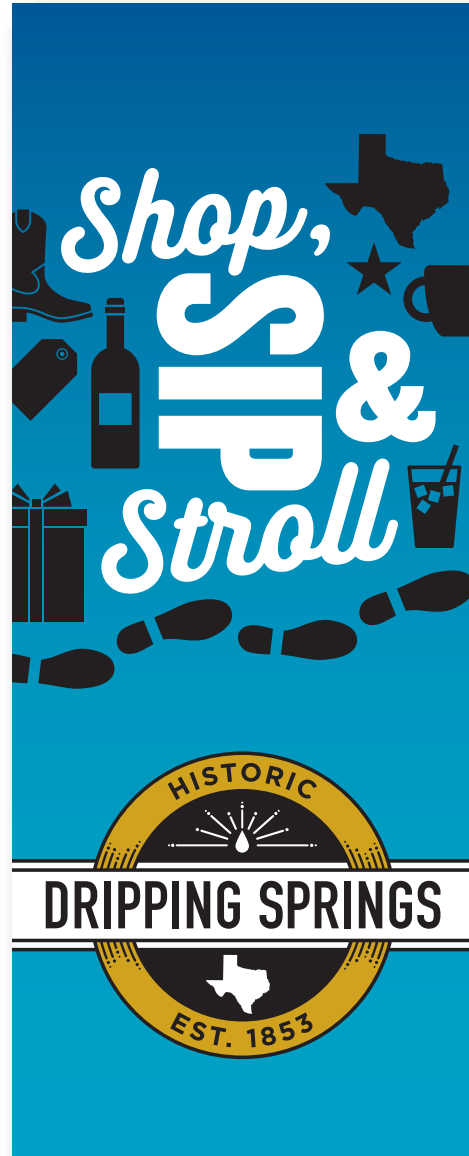

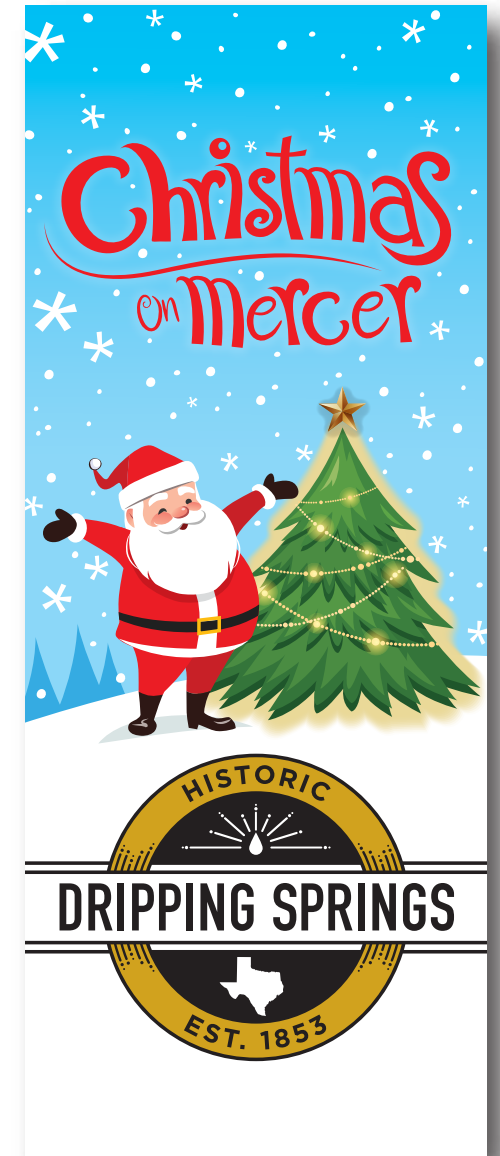
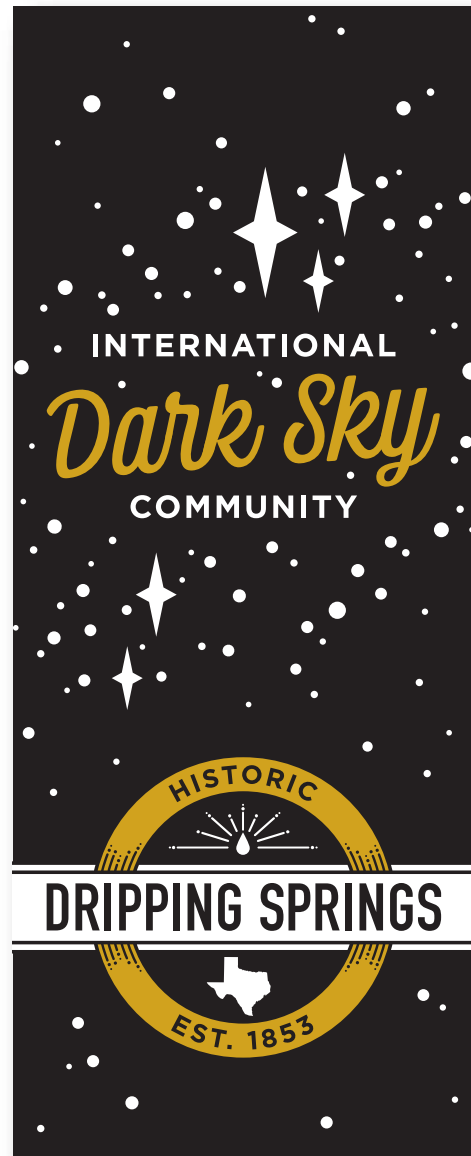
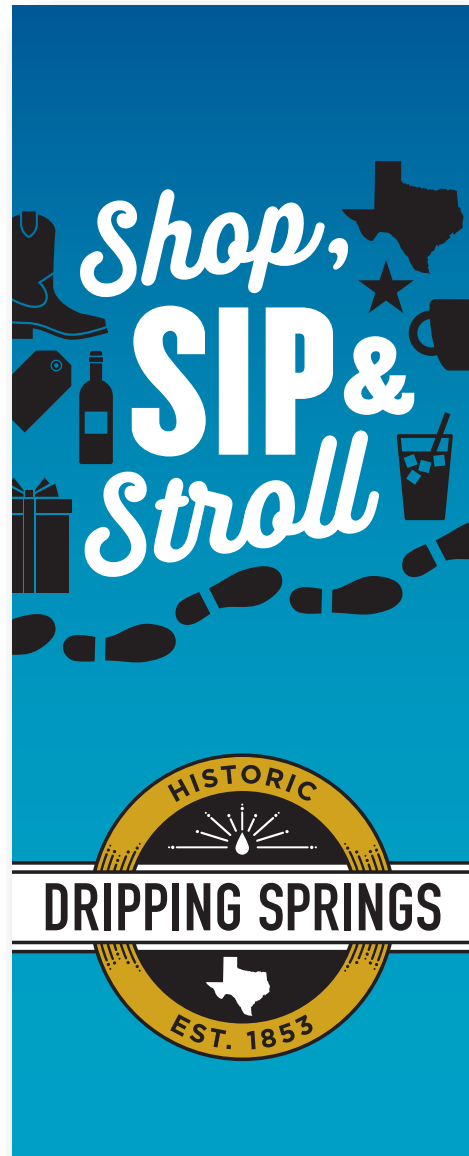





Item 9.

Christmas  
on Merce

70

